

Condominium Documents



PEACHTREEWALK
+A CONDOMINIUM+

1074 PEACHTREE WALK, ATLANTA, GA 30309

1074 Peachtree Walk
Atlanta, Georgia 30309
(404) 892-7400

Important Notice

Any page of this document which reads "Not Original" in the footer of the page indicates that the document was converted from paper to text via Optical Character Recognition (OCR). Although efforts were made to correct any errors created in the conversion process, errors may exist in this document that could significantly change the meaning of a sentence, phrase, or section.

As such, these documents are NOT ORIGINAL and are non-binding representations of the original instruments. The contents of this document have not been ratified by the Peachtree Walk Board of Directors, Owners, or any other interested party.

Niles Bolton Associates, Inc.

■ ■ ■ One Buckhead Plaza
■ ■ ■ 3080 Peachtree Road, NW.
■ ■ ■ Suite 600
■ ■ ■ Atlanta, Georgia
■ ■ ■ 404-365-7600
■ ■ ■ Fax 404-365-7610
■ ■ ■ nba@nilesbolton.com

PEACHTREE WALK

A CONDOMINIUM

Atlanta, Georgia

DISCLOSURE PACKAGE FLOOR PLANS

THE ATTACHED BUILDING AND UNIT FLOOR PLANS HAVE BEEN PREPARED BY NILES BOLTON ASSOCIATES ARCHITECTS. THESE FLOOR PLANS ARE CONCEPTUAL IN NATURE AND SUBJECT TO REVISION. SQUARE FOOTAGE IS APPROXIMATE. PLANS ARE NOT TO SCALE, FINAL PARTITION LAYOUT MAY VARY.

G. NILES BOLTON, AIA,
PRESIDENT
NILES BOLTON ASSOCIATES, INC.

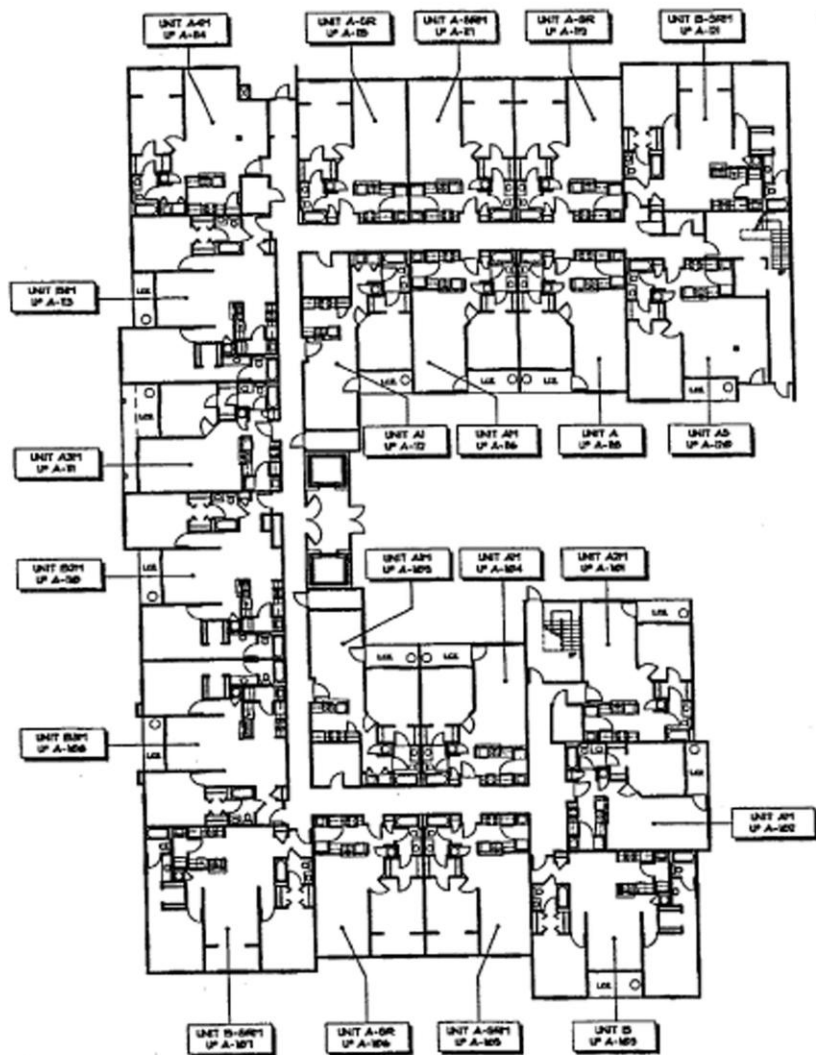

A BUILDING 100

First Level

THE FLOOR PLAN AND THE DIMENSIONS AND SQUARE FOOTAGE
CALCULATIONS SHOWN HEREBY ARE ONLY APPROXIMATIONS. ANY
UNIT OWNER WHO IS CONCERNED ABOUT ANY REPRESENTATIONS
REGARDING THIS FLOOR PLAN SHOULD DO HIS/HER OWN
INVESTIGATION AS TO THE DIMENSIONS, MEASUREMENTS, AND
SQUARE FOOTAGE OF THE UNIT.

PEACHTREE WALK, A CONDOMINIUM

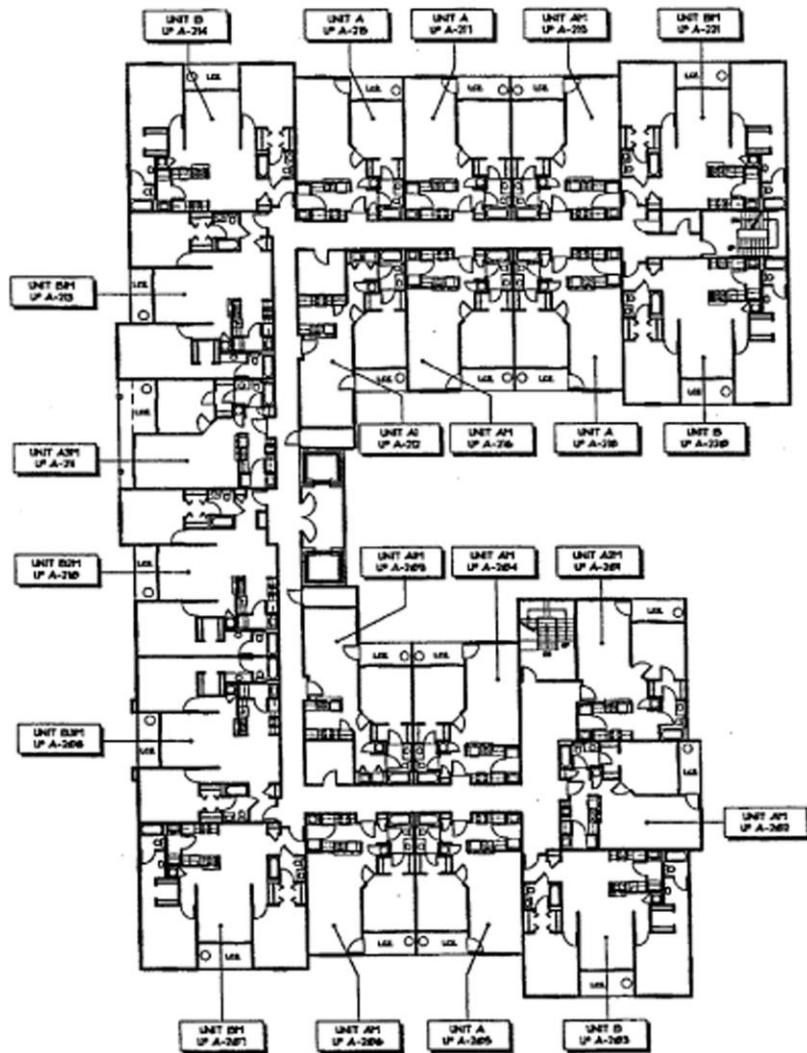

A BUILDING 100

Second Level

THIS FLOOR PLAN AND THE DIMENSIONS AND SQUARE FOOTAGE CALCULATIONS SHOWN HEREIN ARE ONLY APPROXIMATE. ANY UNIT OWNER WHO IS CONCERNED ABOUT ANY REPRESENTATIONS REGARDING THIS FLOOR PLAN SHOULD CONSULT WITH THE ARCHITECT AS TO THE DIMENSIONS, MEASUREMENTS, AND SQUARE FOOTAGE OF THE UNIT.

PEACHTREE WALK, A CONDOMINIUM

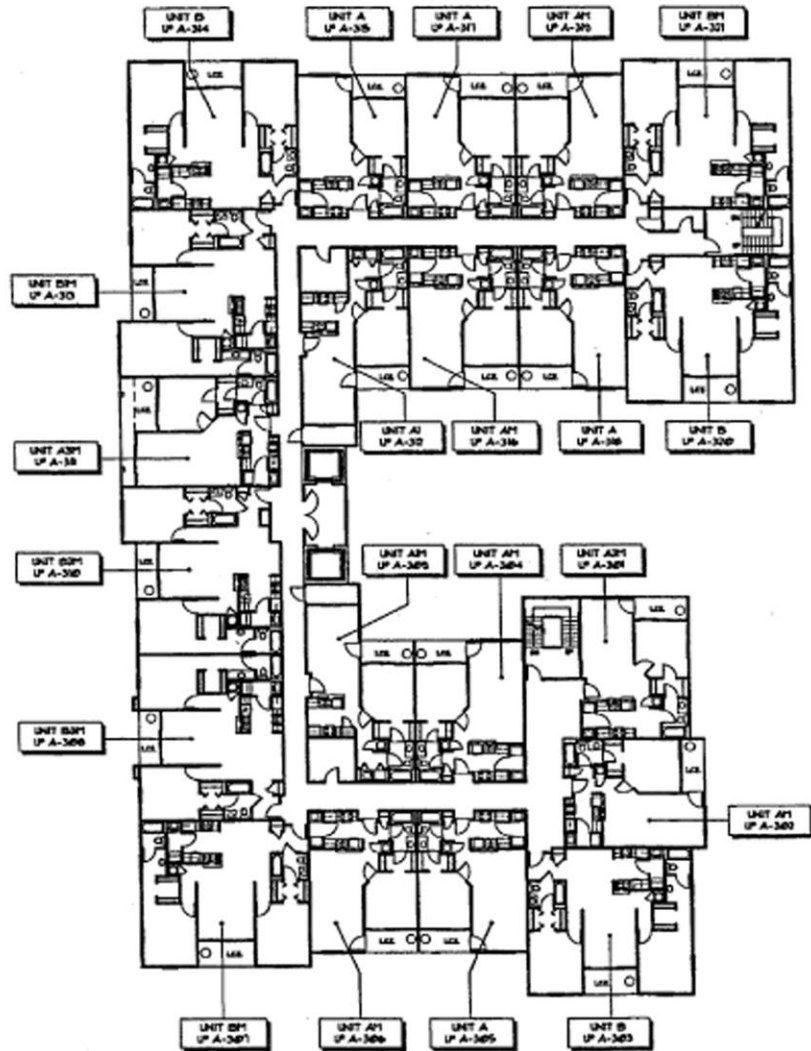

A BUILDING 100

Third Level

THIS FLOOR PLAN AND THE DIMENSIONS AND SQUARE FOOTAGE CALCULATIONS SHOWN HEREIN ARE ONLY APPROXIMATIONS. ANY USER OWNER WHO IS CONCERNED ABOUT ANY REPRESENTATIONS REGARDING THIS FLOOR PLAN SHOULD DO HEAVIER DUE DILIGENCE AS TO THE DIMENSIONS, MEASUREMENTS, AND SQUARE FOOTAGE OF THE UNIT.

PEACHTREE WALK, A CONDOMINIUM

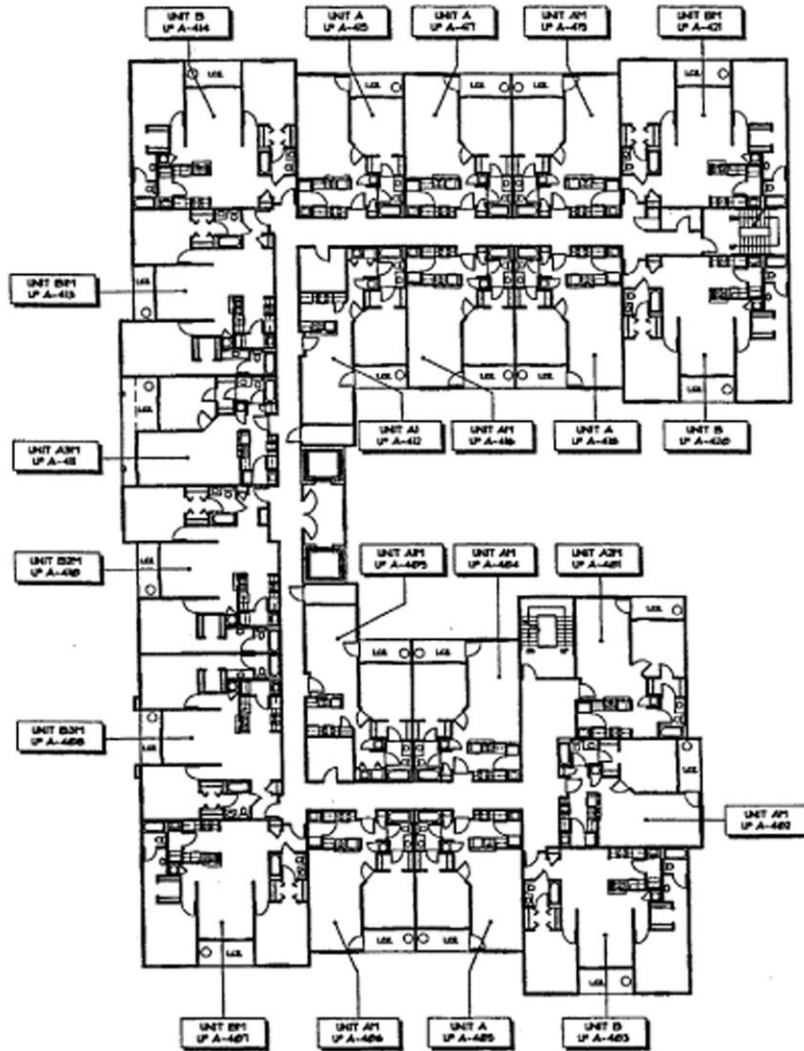

A BUILDING 100

Fourth Level

THE FLOOR PLAN AND THE DIMENSIONS AND SQUARE FOOTAGE CALCULATIONS SHOWN HEREIN ARE ONLY APPROXIMATIONS. ANY UNIT OWNER WHO IS CONCERNED ABOUT ANY REPRESENTATIONS REGARDING THE FLOOR PLAN SHOULD DO HIS/HER OWN INVESTIGATION AS TO THE DIMENSIONS, MEASUREMENTS, AND SQUARE FOOTAGE OF THE UNIT.

PEACHTREE WALK, A CONDOMINIUM

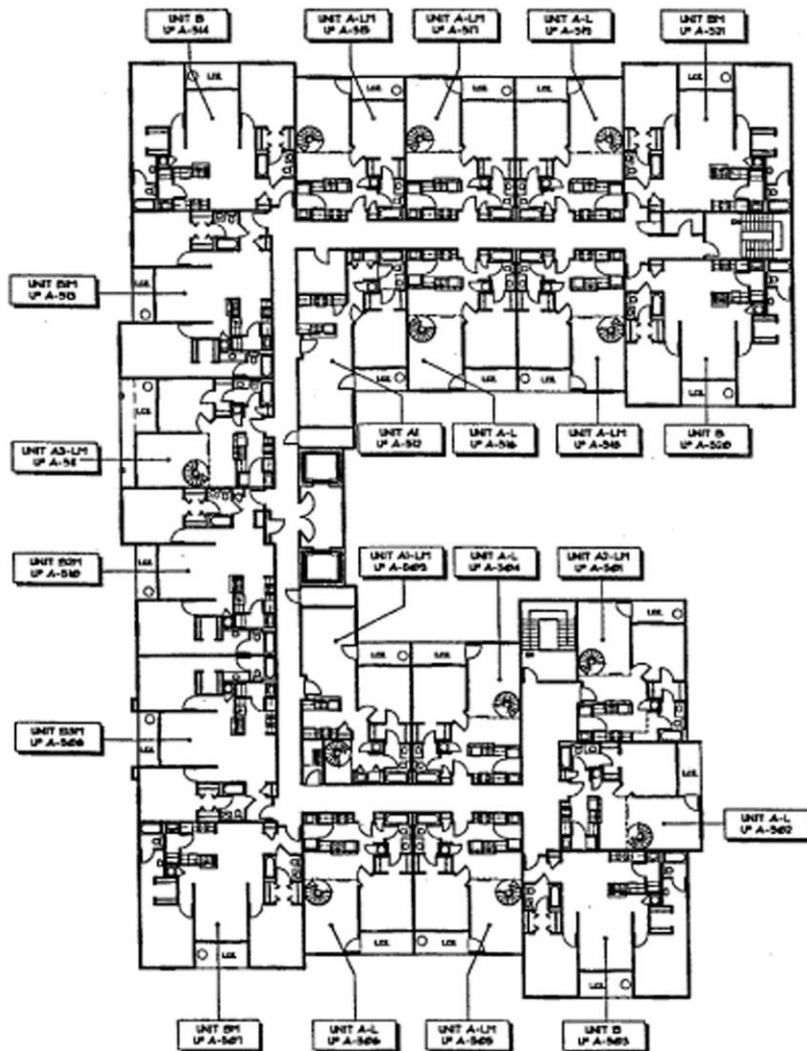

A BUILDING 100

Fifth Level

THIS FLOOR PLAN AND THE DIMENSIONS AND SQUARE FOOTAGE CALCULATIONS SHOWN HEREON ARE ONLY APPROXIMATE. ANY UNIT OWNER WHO IS CONCERNED ABOUT ANY REPRESENTATIONS REGARDING THIS FLOOR PLAN SHOULD DO HIS OR HER OWN INVESTIGATION AS TO THE DIMENSIONS, MEASUREMENTS, AND SQUARE FOOTAGE OF THE UNIT.

PEACHTREE WALK, A CONDOMINIUM

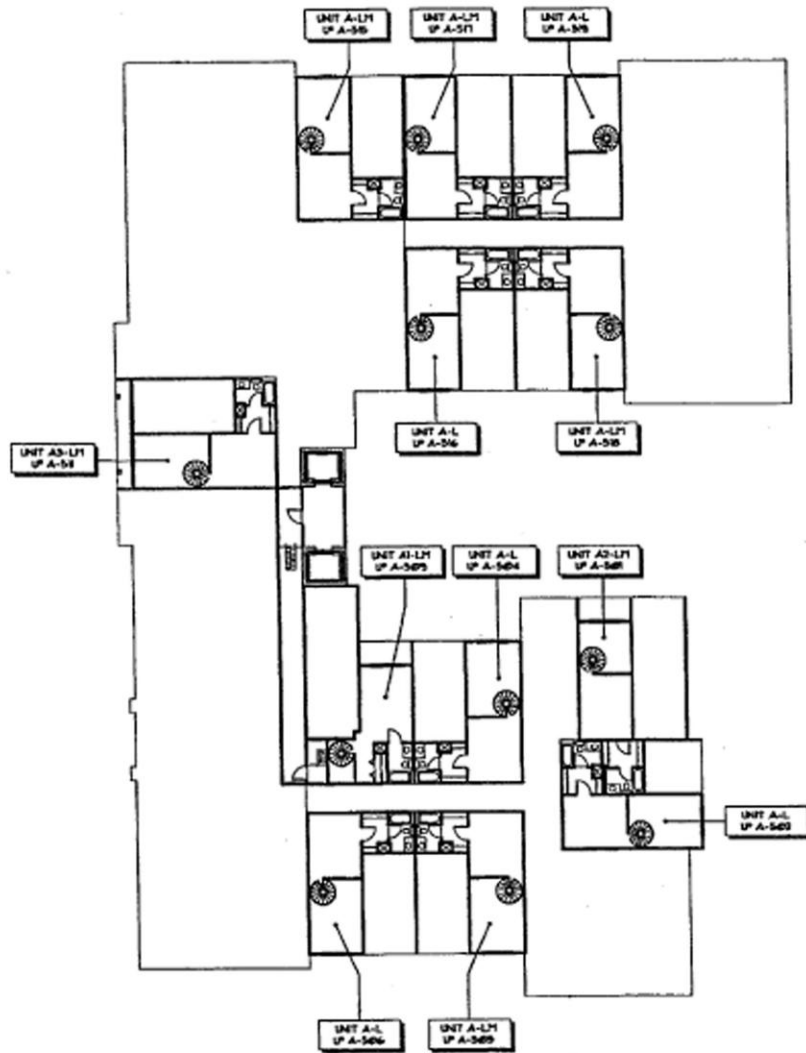

A BUILDING 100

Loft Level

THE FLOOR PLAN AND THE DIMENSIONS AND SQUARE FOOTAGE
CALCULATIONS SHOWN HEREIN ARE ONLY APPROXIMATIONS. ANY
UNIT OWNER WHO IS CONCERNED ABOUT ANY REPRESENTATIONS
REGARDING THE FLOOR PLAN SHOULD DO FURTHER DUE
DILIGENCE AS TO THE DIMENSIONS, MEASUREMENTS, AND
SQUARE FOOTAGE OF THE UNIT.

PEACHTREE WALK, A CONDOMINIUM

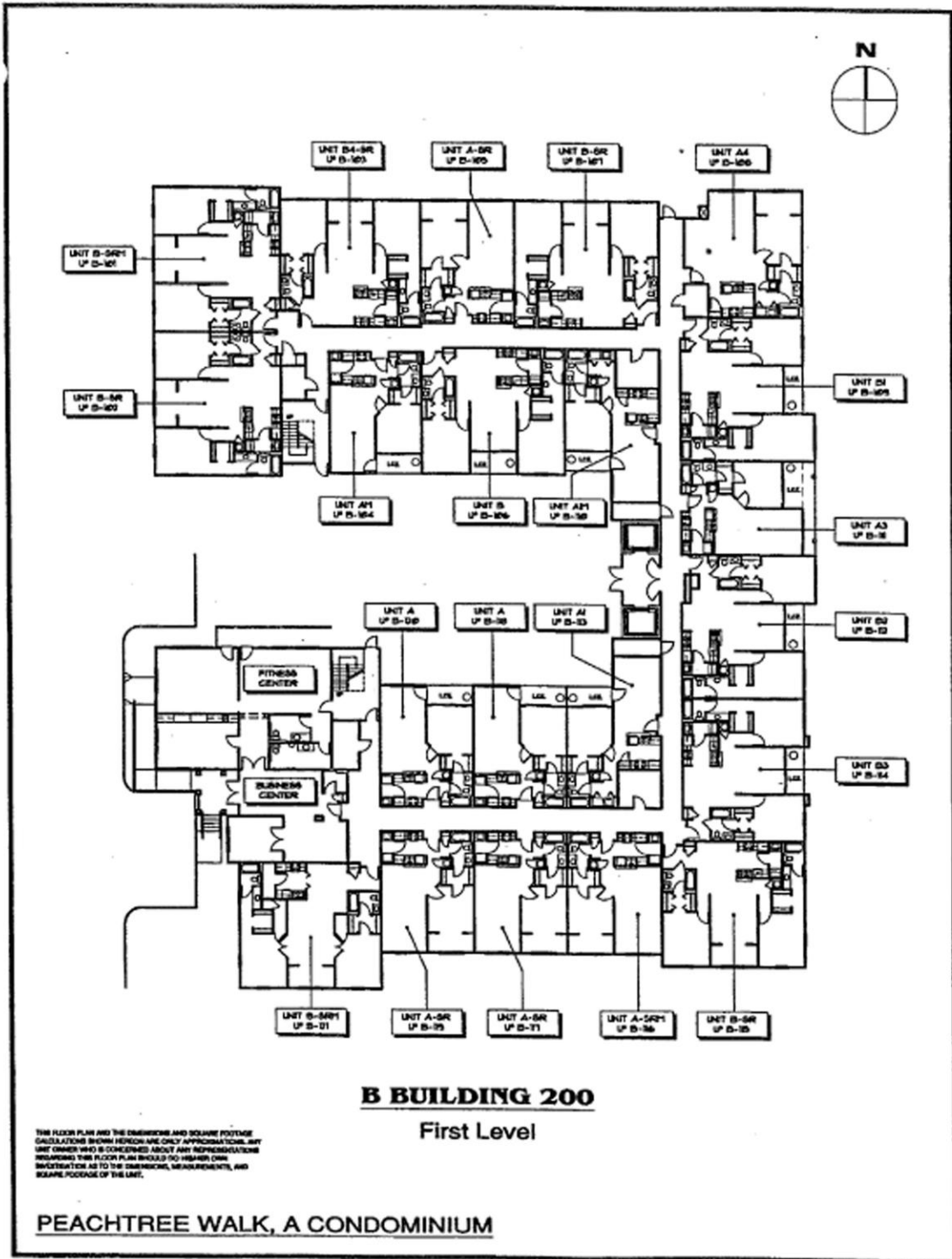

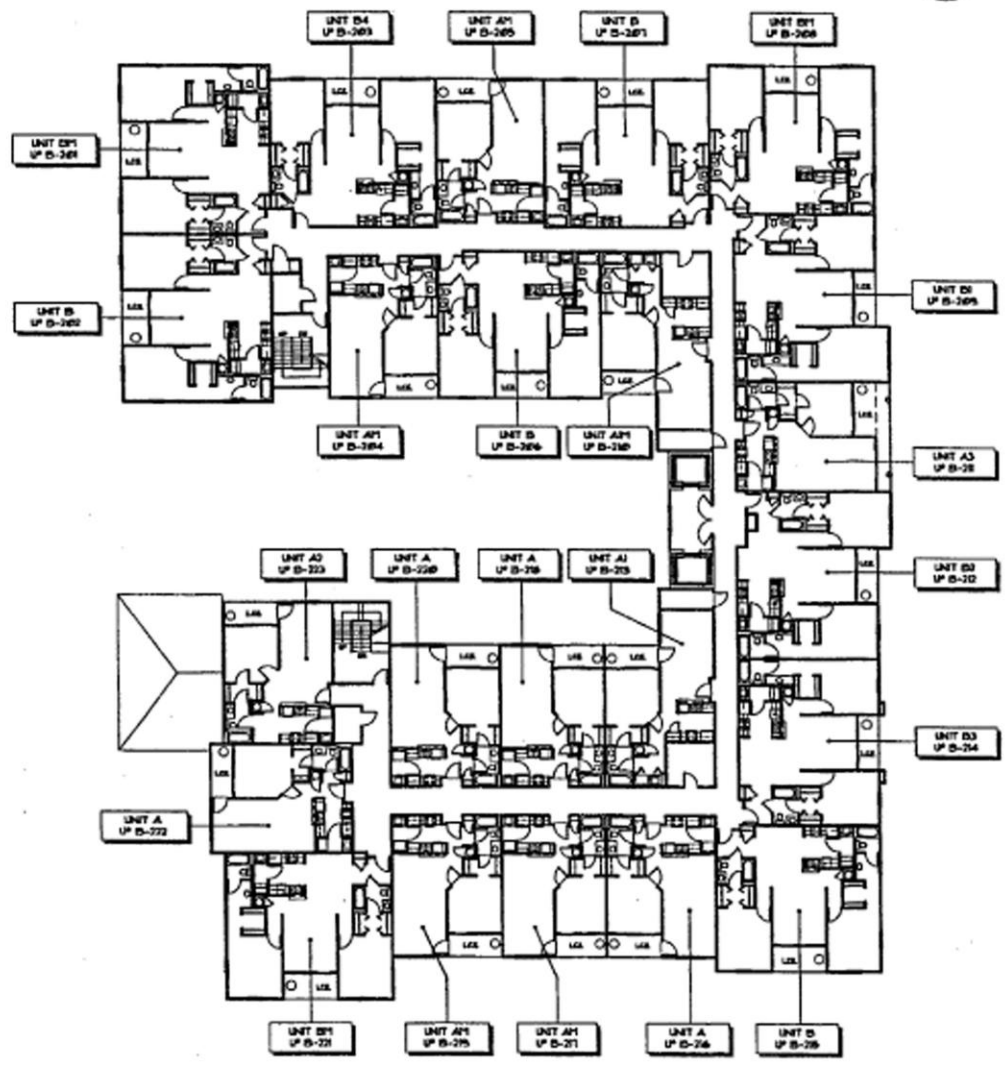
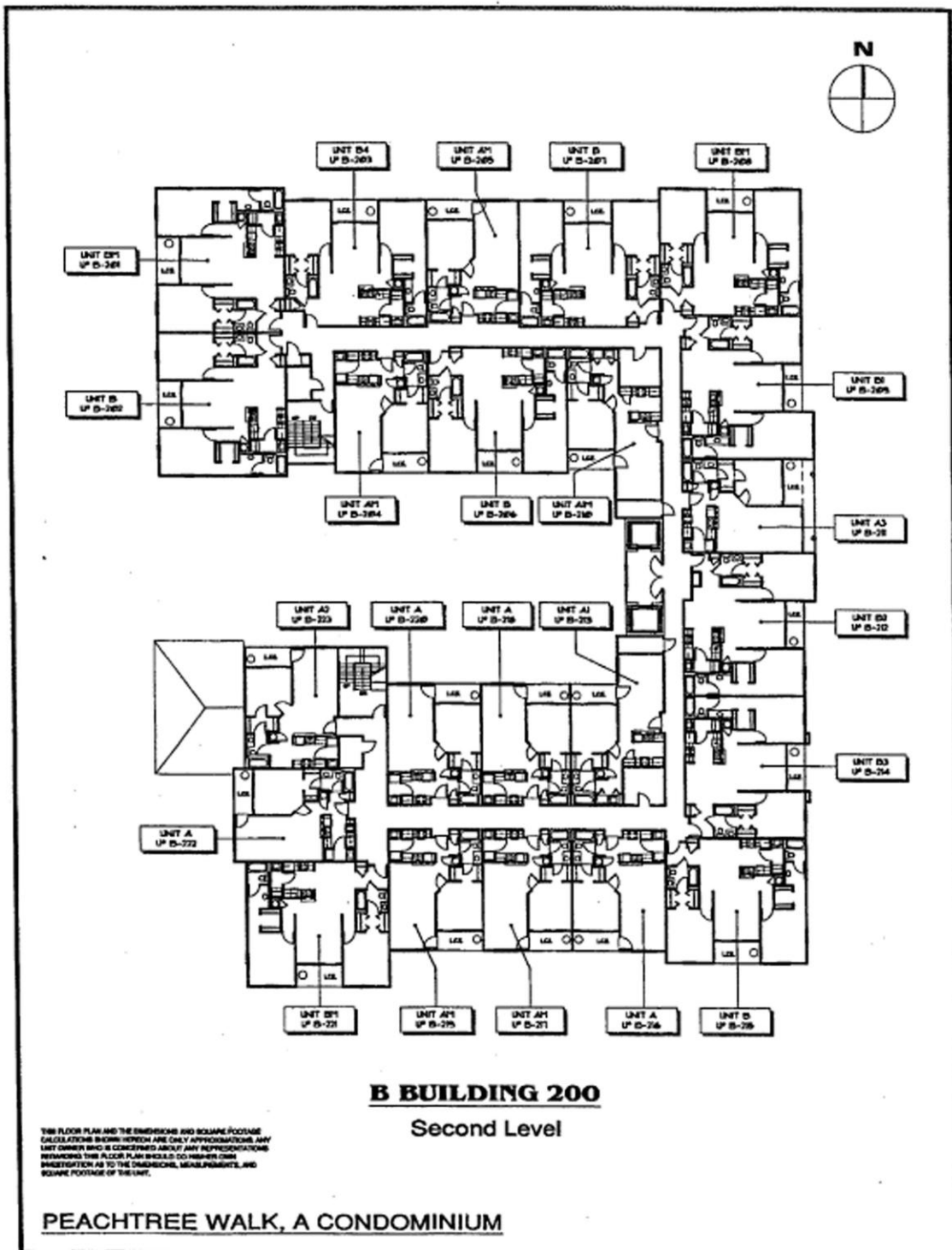

B BUILDING 200
Second Level

THIS FLOOR PLAN AND THE DIMENSIONS AND SQUARE FOOTAGE CALCULATIONS SHOWN HEREON ARE ONLY APPROXIMATIONS. ANY UNIT OWNER WHO IS CONCERNED ABOUT ANY REPRESENTATIONS REGARDING THIS FLOOR PLAN SHOULD DO FURTHER OWN INVESTIGATION AS TO THE DIMENSIONS, MEASUREMENTS, AND SQUARE FOOTAGE OF THE UNIT.

PEACHTREE WALK, A CONDOMINIUM

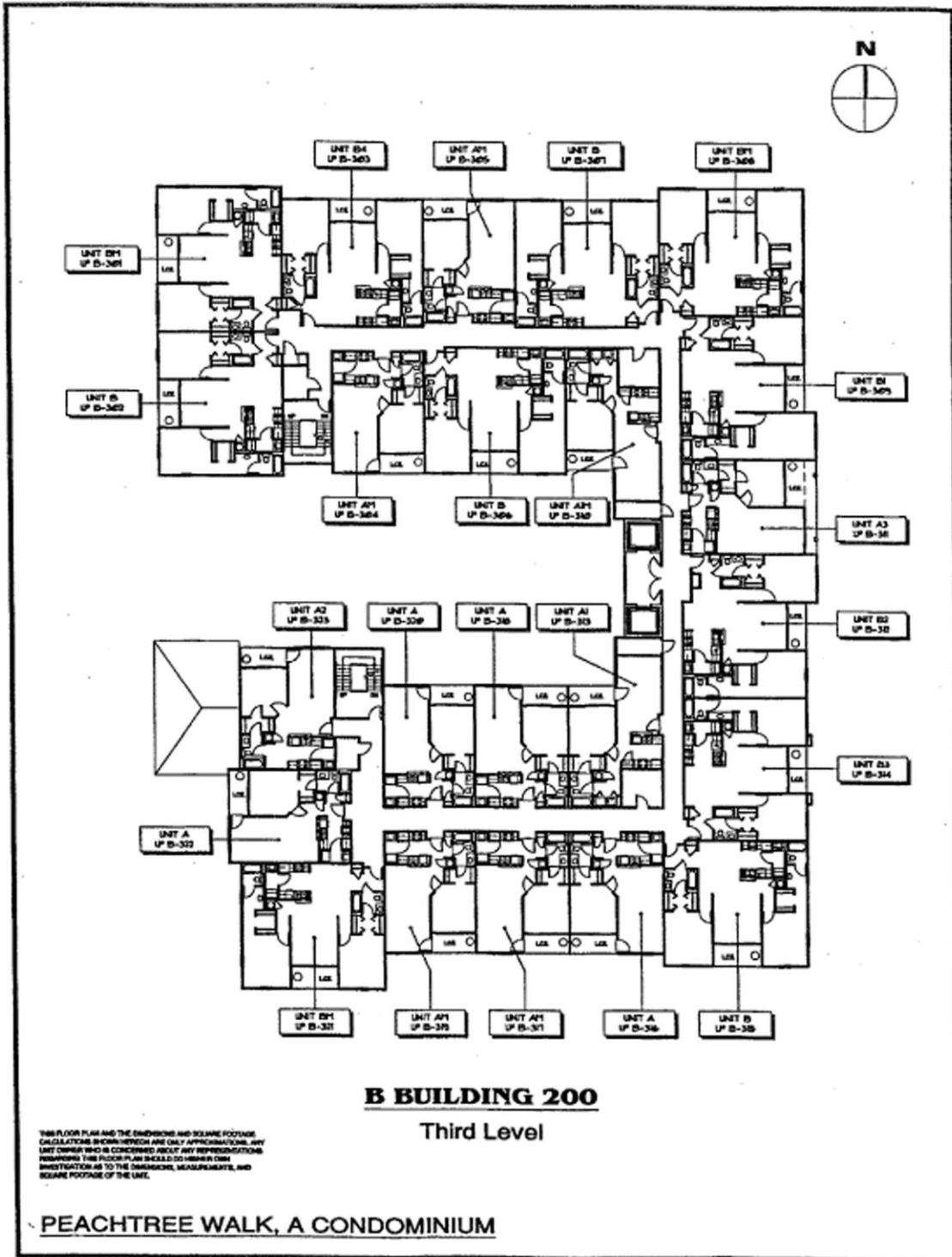

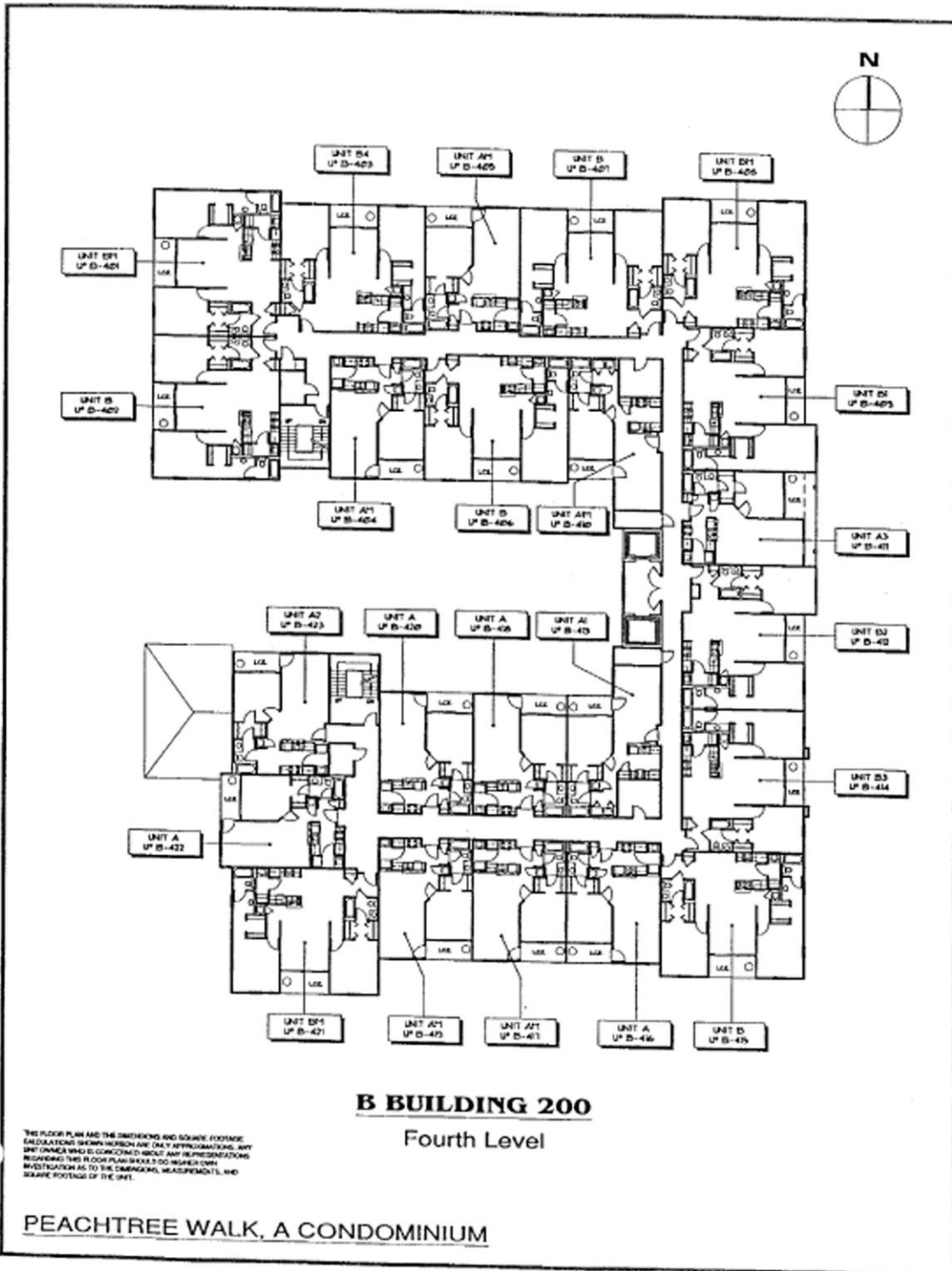

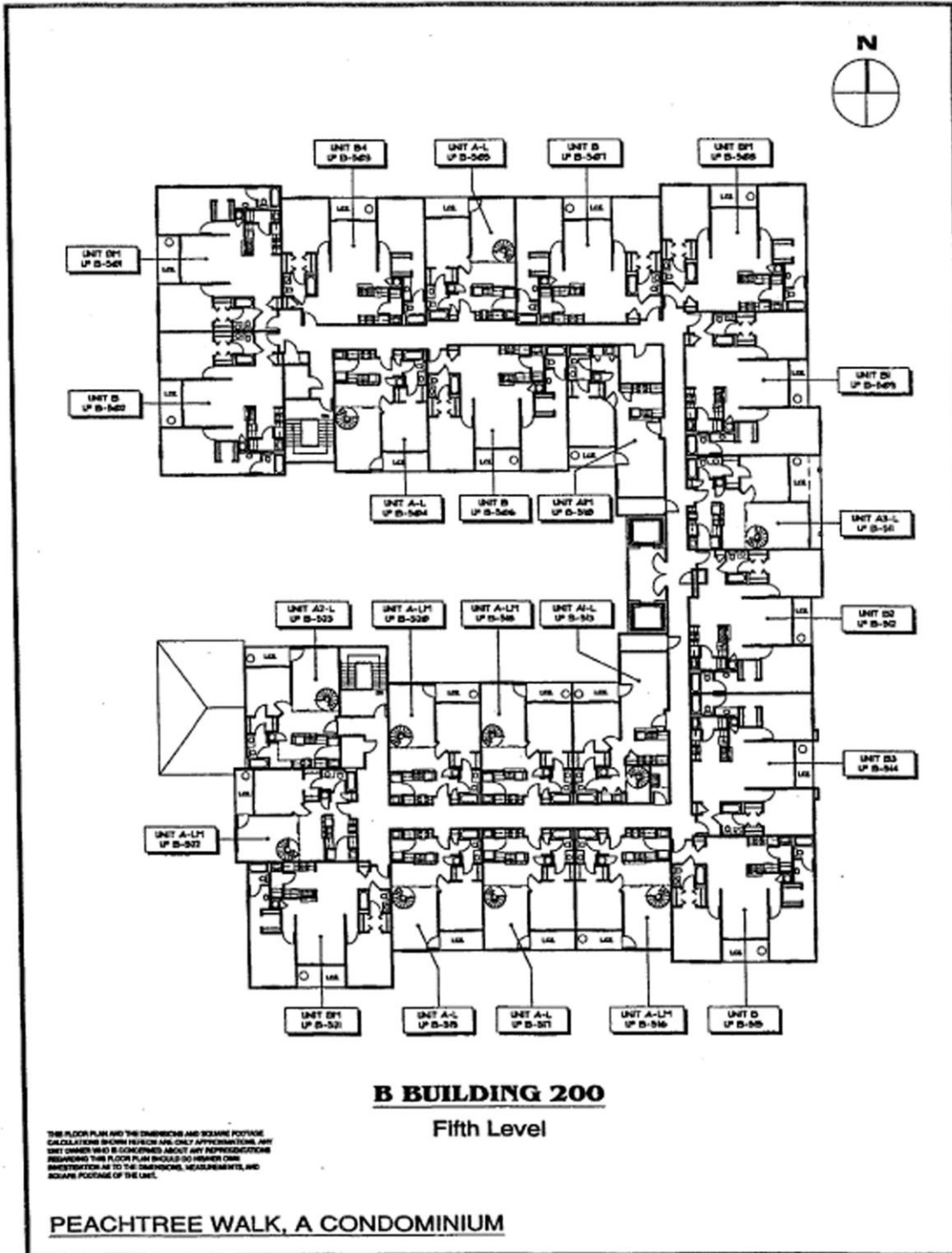

B BUILDING 200

Fifth Level

THIS FLOOR PLAN AND THE DIMENSIONS AND SQUARE FOOTAGE CALCULATIONS SHOWN THEREON ARE ONLY APPROXIMATIONS. ANY UNIT OWNER WHO IS CONCERNED ABOUT ANY REPRESENTATIONS RELATING THIS FLOOR PLAN SHOULD DO HIS/HER OWN INVESTIGATION AS TO THE DIMENSIONS, MEASUREMENTS, AND SQUARE FOOTAGE OF THE UNIT.

PEACHTREE WALK, A CONDOMINIUM

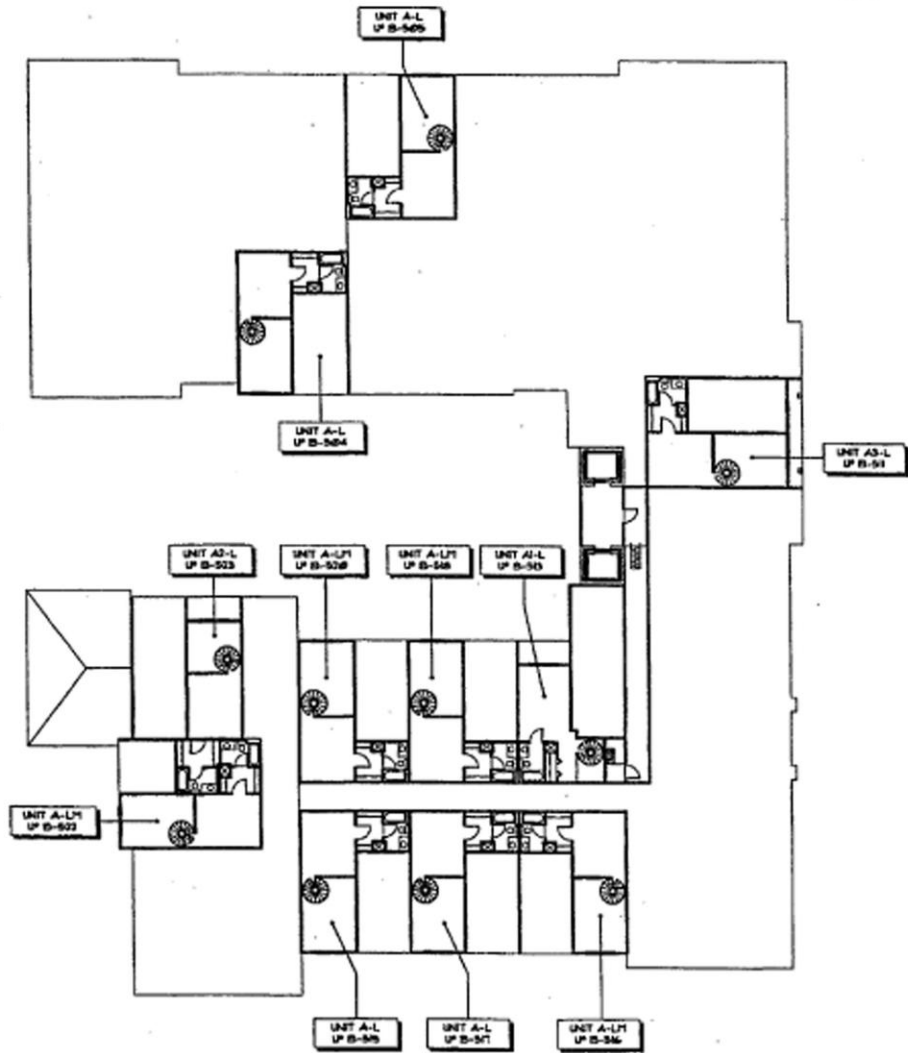

B BUILDING 200

Loft Level

THIS FLOOR PLAN AND THE DIMENSIONS AND SQUARE FOOTAGE
CALCULATIONS SHOWN HEREIN ARE ONLY APPROXIMATIONS. ANY
UNIT OWNER WHO IS CONSIDERING ACQUIRING ANY REPRESENTATIONS
REGARDING THIS FLOOR PLAN SHOULD DO HER/HER OWN
INDEPENDENT AS TO THE DIMENSIONS, MEASUREMENTS, AND
SQUARE FOOTAGE OF THE UNIT.

PEACHTREE WALK, A CONDOMINIUM

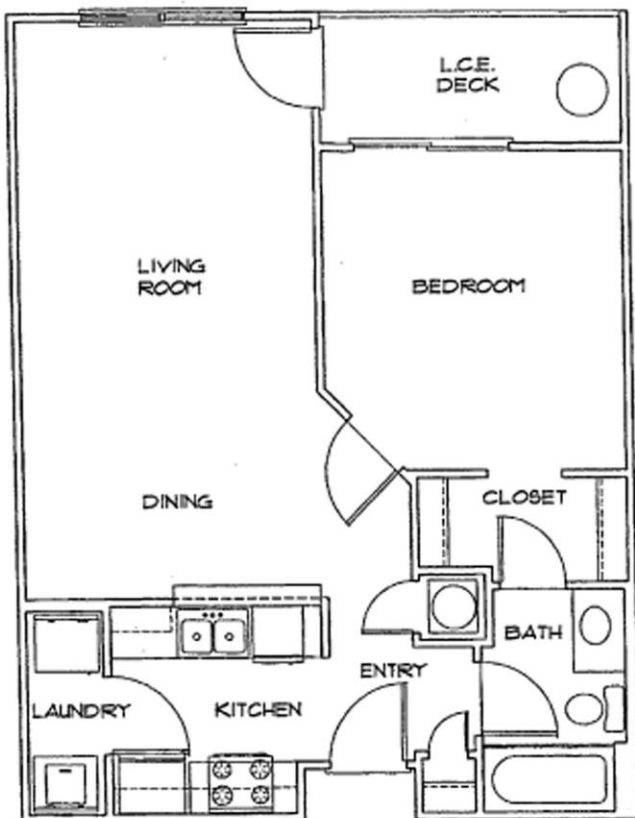

UNIT A - DECK

1 Bedroom - 1 Bath

UNIT NUMBERS:

A-118, A-205, A-215, A-217, A-218,
 A-305, A-315, A-317, A-318, A-405,
 A-415, A-417, A-418
 B-118, B-120, B-216, B-218, B-220,
 B-222, B-316, B-318, B-320, B-322,
 B-416, B-418, B-420, B-422

THIS FLOOR PLAN AND THE DIMENSIONS AND SQUARE FOOTAGE
 CALCULATIONS SHOWN HEREON ARE ONLY APPROXIMATIONS. ANY
 UNIT OWNER WHO IS CONCERNED ABOUT ANY REPRESENTATIONS
 REGARDING THIS FLOOR PLAN SHOULD CONSULT WITH THE
 ARCHITECT FOR A MORE DETAILED INVESTIGATION AS TO THE DIMENSIONS, MEASUREMENTS, AND
 SQUARE FOOTAGE OF THE UNIT.

PEACHTREE WALK, A CONDOMINIUM

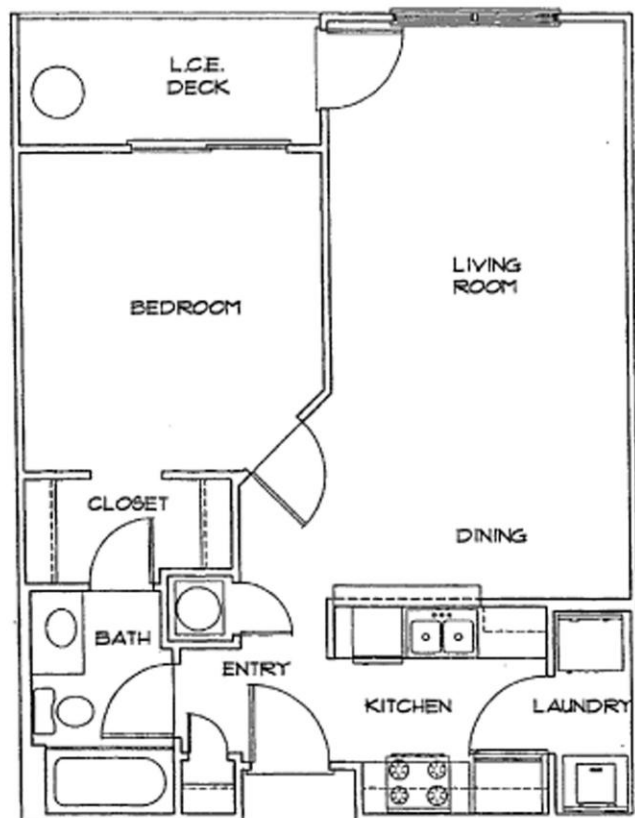

UNIT A - DECK (M)

1 Bedroom - 1 Bath

UNIT NUMBERS:

A-102, A-104, A-116, A-202, A-204,
 A-206, A-216, A-219, A-302, A-304,
 A-306, A-316, A-319, A-402, A-404,
 A-406, A-416, A-419
 B-104, B-204, B-205, B-217, B-219,
 B-304, B-305, B-317, B-319, B-404,
 B-405, B-417, B-419

THE FLOOR PLAN AND THE DIMENSIONS AND SQUARE FOOTAGE
 CALCULATIONS SHOWN HEREIN ARE ONLY APPROXIMATIONS. ANY
 UNIT OWNER WHO IS CONCERNED ABOUT ANY NON-CONFORMITIES
 REGARDING THE FLOOR PLAN SHOULD SO BEWARE ONLY
 REFER TO THE DIMENSIONS, MEASUREMENTS, AND
 SQUARE FOOTAGE OF THE UNIT.

PEACHTREE WALK, A CONDOMINIUM

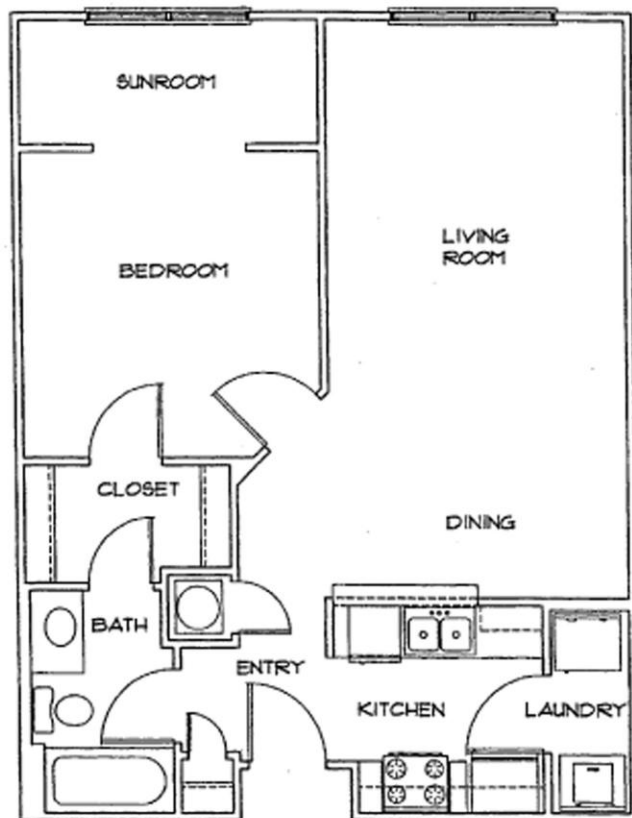

UNIT A - SUNROOM

1 Bedroom - 1 Bath

UNIT NUMBERS:

A-106, A-115, A-119

B-105, B-117, B-119

THIS FLOOR PLAN AND THE DIMENSIONS AND SQUARE FOOTAGE
CALCULATIONS SHOWN THEREIN ARE ONLY APPROXIMATIONS AND
NEITHER SHOULD BE CONSIDERED NOR ANY REPRESENTATIONS
REGARDING THE FLOOR PLAN SHOULD GO NEARER OR
INVESTIGATION AS TO THE DIMENSIONS, MEASUREMENTS, AND
SQUARE FOOTAGE OF THE UNIT.

PEACHTREE WALK, A CONDOMINIUM

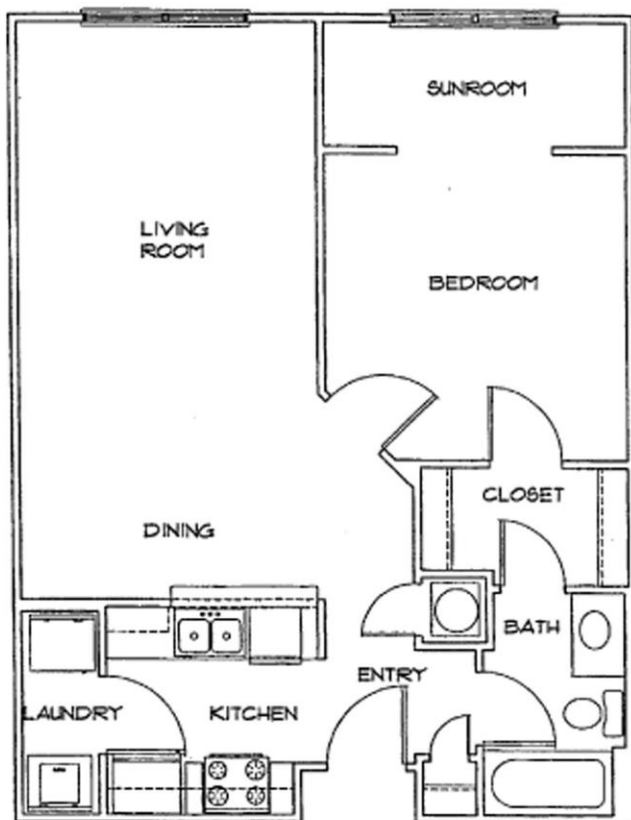

UNIT A - SUNROOM (M)

1 Bedroom - 1 Bath

UNIT NUMBERS:

A-105, A-117

B-116

THIS FLOOR PLAN AND THE DIMENSIONS AND SQUARE FOOTAGE
 INDICATED THEREIN ARE ONLY APPROXIMATIONS. ANY
 UNIT OWNER WHO IS CONCERNED ABOUT ANY DISCREPANCIES
 REGARDING THIS FLOOR PLAN SHOULD DO HIS/HER OWN
 INVESTIGATION AS TO THE DIMENSIONS, MEASUREMENTS, AND
 SQUARE FOOTAGE OF THE UNIT.

PEACHTREE WALK, A CONDOMINIUM

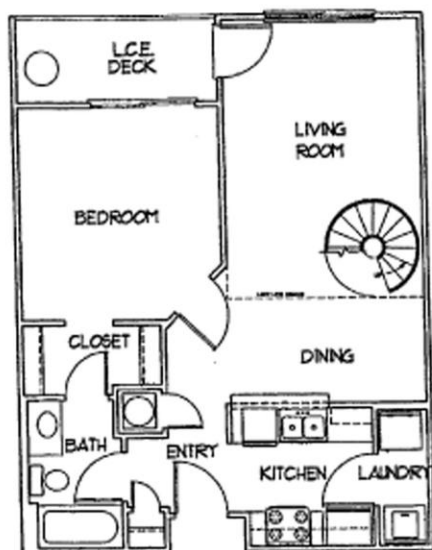

First Level

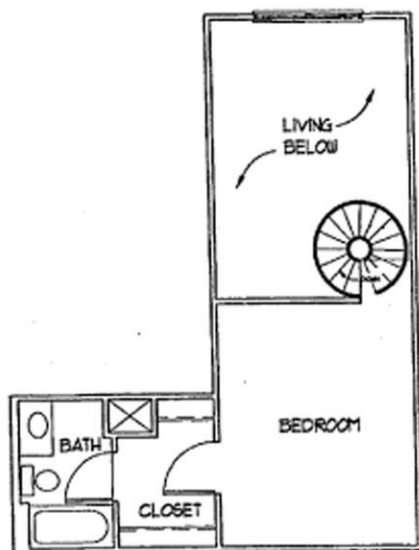

Second Level

UNIT A - LOFT

2 Bedroom - 2 Bath

UNIT NUMBERS:

A-502, A-504, A-506, A-516, A-519
 B-504, B-505, B-517, B-519

THIS FLOOR PLAN AND THE DIMENSIONS AND SQUARE FOOTAGE
 CALCULATIONS SHOWN HEREON ARE ONLY APPROXIMATIONS. ANY
 UNIT OWNER WHO IS CONCERNED ABOUT ANY REPRESENTATIONS
 INTRODUCED THIS FLOOR PLAN SHOULD DO HIS/HER OWN
 INVESTIGATION AS TO THE DIMENSIONS, MEASUREMENTS, AND
 SQUARE FOOTAGE OF THE UNIT.

PEACHTREE WALK, A CONDOMINIUM

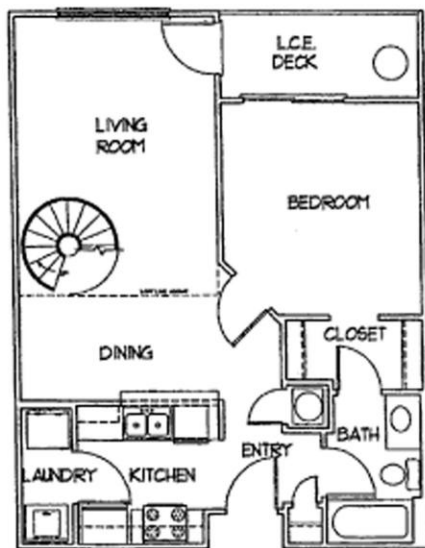

First Level

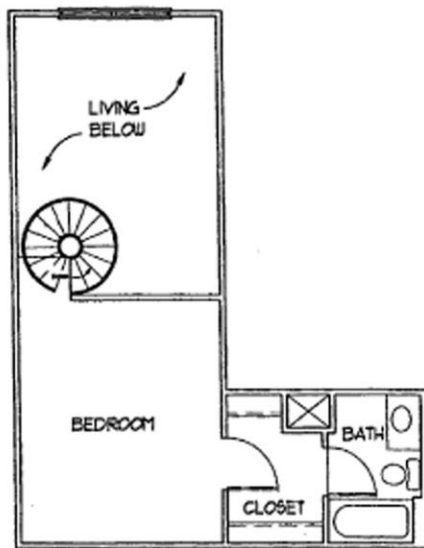

Second Level

UNIT A - LOFT (M)

2 Bedroom - 2 Bath

UNIT NUMBERS:

A-505, A-515, A-517, A-518
B-516, B-518, B-520, B-522

THIS FLOOR PLAN AND THE DIMENSIONS AND SQUARE FOOTAGE CALCULATIONS SHOWN HEREIN ARE ONLY APPROXIMATIONS. ANY UNIT OWNER WHO IS CONCERNED ABOUT ANY REPRESENTATIONS REGARDING THIS FLOOR PLAN SHOULD CONSULT HIS OR HER ARCHITECT FOR AS TO THE DIMENSIONS, MEASUREMENTS, AND SQUARE FOOTAGE OF THE UNIT.

PEACHTREE WALK, A CONDOMINIUM

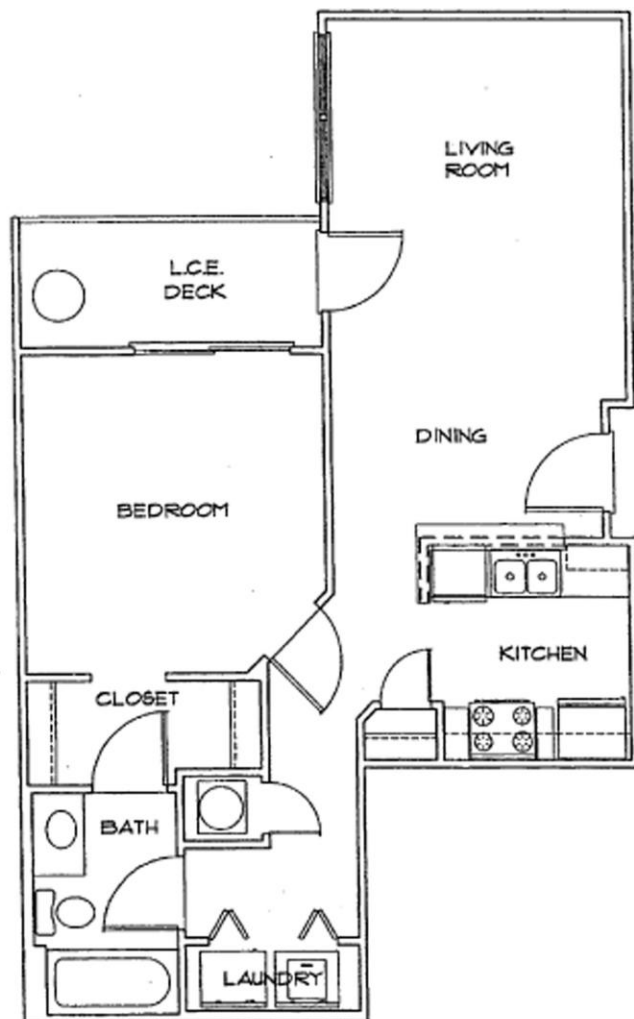

UNIT NUMBERS:
 A-112, A-212, A-312, A-412, A-512
 B-113, B-213, B-313, B-413

UNIT A1
 1 Bedroom - 1 Bath

THIS FLOOR PLAN AND THE DIMENSIONS AND SQUARE FOOTAGE
 CALCULATIONS SHOWN HEREON ARE ONLY APPROXIMATIONS. ANY
 UNIT OWNER WHO IS CONCERNED ABOUT ANY REPRESENTATIONS
 REGARDING THIS FLOOR PLAN SHOULD CONSULT WITH A
 SURVEYOR AS TO THE DIMENSIONS, REQUIREMENTS, AND
 SQUARE FOOTAGE OF THE UNIT.

PEACHTREE WALK, A CONDOMINIUM

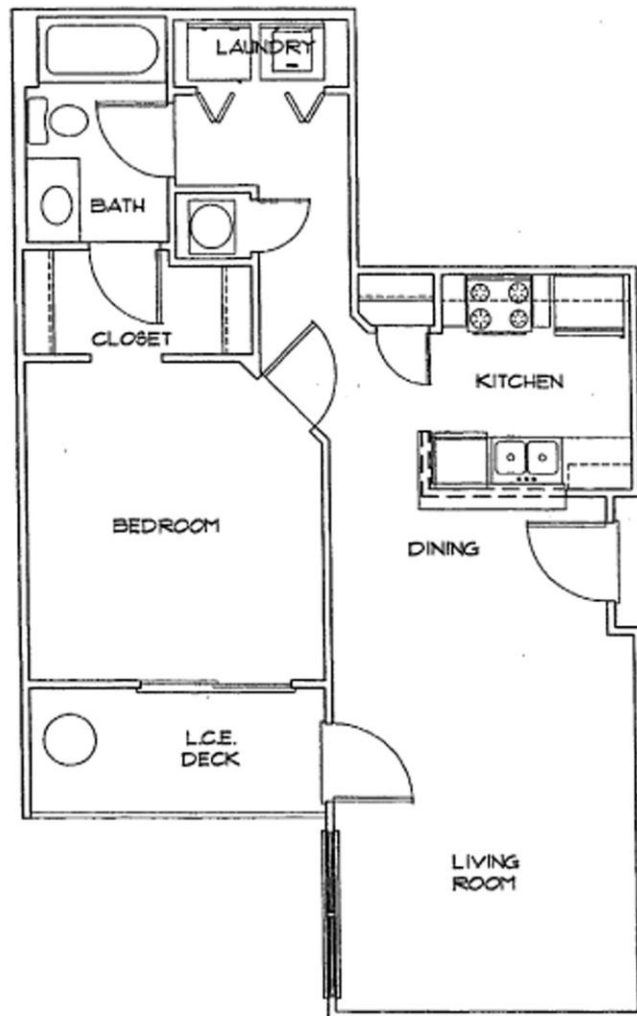

UNIT NUMBERS:

A-109, A-209, A-309, A-409
 B-110, B-210, B-310, B-410, B-510

UNIT A1 (M)

1 Bedroom - 1 Bath

THE FLOOR PLAN AND THE DIMENSIONS AND SQUARE FOOTAGE
 CALCULATIONS SHOWN HEREON ARE ONLY APPROXIMATIONS. ANY
 UNIT OWNER WHO IS CONCERNED ABOUT ANY DISCREPANCIES
 REGARDING THIS FLOOR PLAN SHOULD SO IMMEDIATELY
 INVESTIGATE AS TO THE DIMENSIONS, MEASUREMENTS, AND
 SQUARE FOOTAGE OF THE UNIT.

PEACHTREE WALK, A CONDOMINIUM

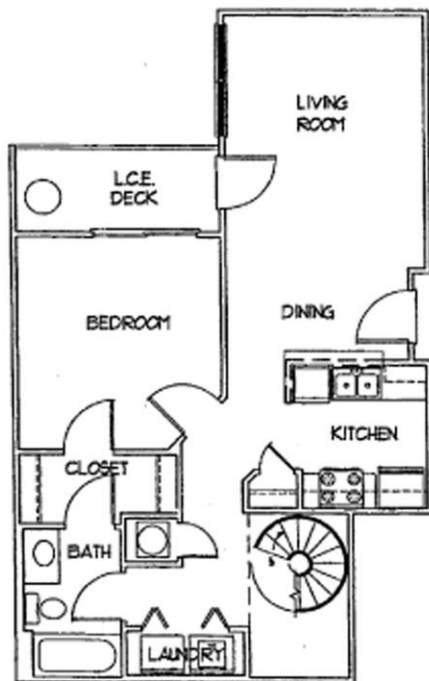

First Level

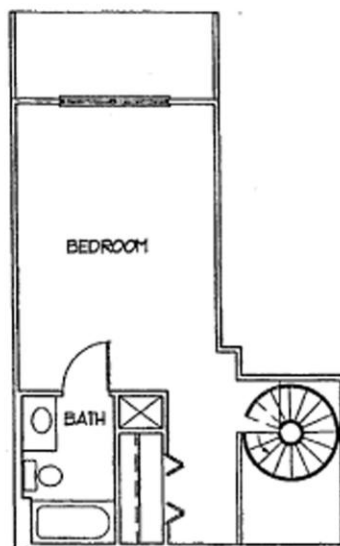

Second Level

UNIT A1 - LOFT

2 Bedroom - 2 Bath

UNIT NUMBERS:
B-513

THIS FLOOR PLAN AND THE DIMENSIONS AND SQUARE FOOTAGE CALCULATIONS SHOWN HEREON ARE ONLY APPROXIMATIONS. ANY UNIT OWNER WHO IS CONCERNED ABOUT ANY REPRESENTATIONS REGARDING THIS FLOOR PLAN SHOULD DO HER/His OWN INVESTIGATION AS TO THE DIMENSIONS, MEASUREMENTS, AND SQUARE FOOTAGE OF THE UNIT.

PEACHTREE WALK, A CONDOMINIUM

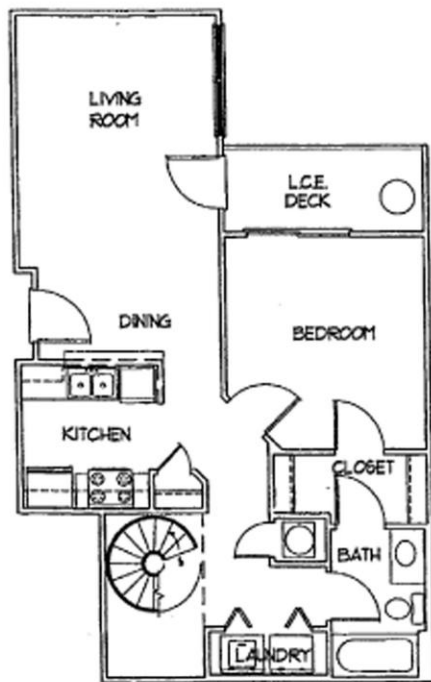

First Level

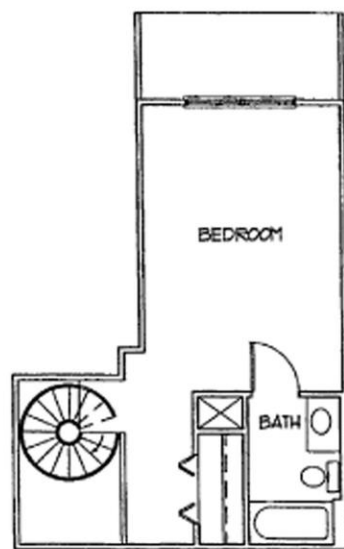

Second Level

UNIT A1 - LOFT (M)

2 Bedroom - 2 Bath

UNIT NUMBERS:
A-503

THIS FLOOR PLAN AND THE DIMENSIONS AND SQUARE FOOTAGE
CALCULATIONS SHOWN HEREON ARE ONLY APPROXIMATIONS. ANY
LINE DRAWING VIEW IS CONSIDERED ABOUT ANY REPRESENTATIONS
REGARDING THE FLOOR PLAN SHALL BE HELD AS NEARLY AS
POSSIBLE TO THE DIMENSIONS, MEASUREMENTS, AND
SQUARE FOOTAGE OF THE UNIT.

PEACHTREE WALK, A CONDOMINIUM

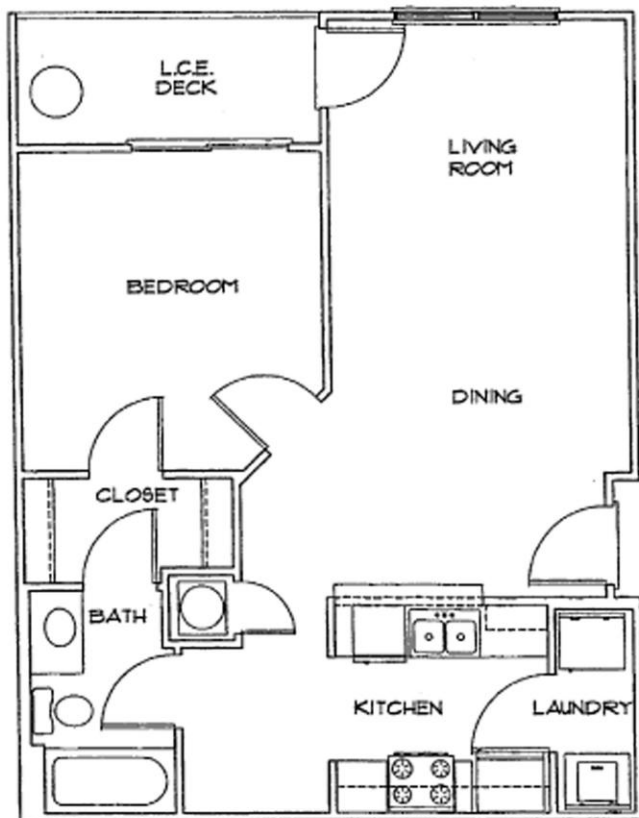

UNIT A2

1 Bedroom - 1 Bath

UNIT NUMBERS:
B-223, B-323, B-423

THIS FLOOR PLAN AND THE DIMENSIONS AND SQUARE FOOTAGE CALCULATIONS SHOWN HEREON ARE ONLY APPROXIMATIONS. ANY UNIT OWNER WHO IS CONCERNED ABOUT ANY REPRESENTATIONS REGARDING THIS FLOOR PLAN SHOULD CONSULT WITH AN INVESTIGATOR AS TO THE DIMENSIONS, MEASUREMENTS, AND SQUARE FOOTAGE OF THE UNIT.

PEACHTREE WALK, A CONDOMINIUM

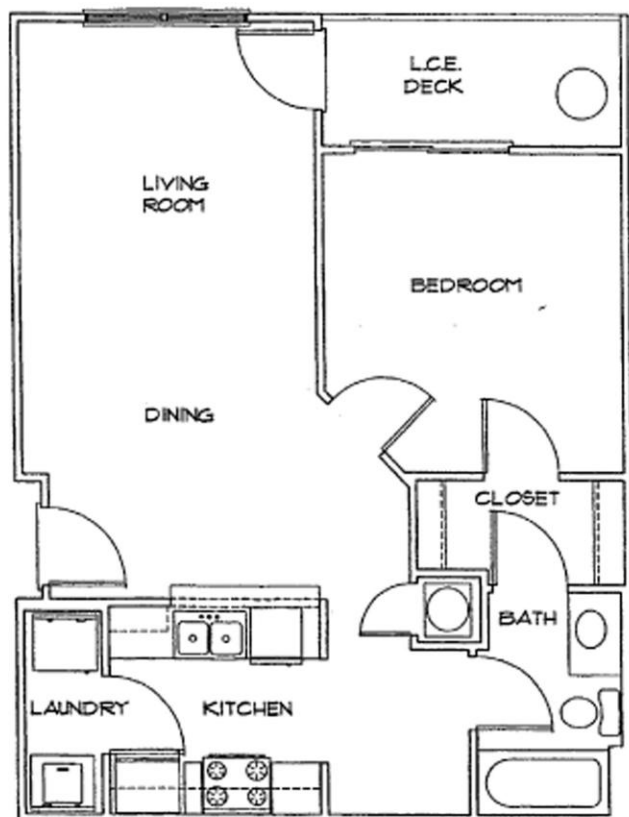

UNIT A2 (M)

1 Bedroom - 1 Bath

UNIT NUMBERS:

A-101, A-201, A-301, A-401

THIS FLOOR PLAN AND THE DIMENSIONS AND SQUARE FOOTAGE
CALCULATIONS SHOWN HEREIN ARE ONLY APPROXIMATIONS. ANY
UNIT OWNER WHO IS CONCERNED ABOUT ANY REPRESENTATIONS
REGARDING THIS FLOOR PLAN SHOULD GO HIS/HER OWN
INDEPENDENT AS TO THE DIMENSIONS, MEASUREMENTS, AND
SQUARE FOOTAGE OF THE UNIT.

PEACHTREE WALK, A CONDOMINIUM

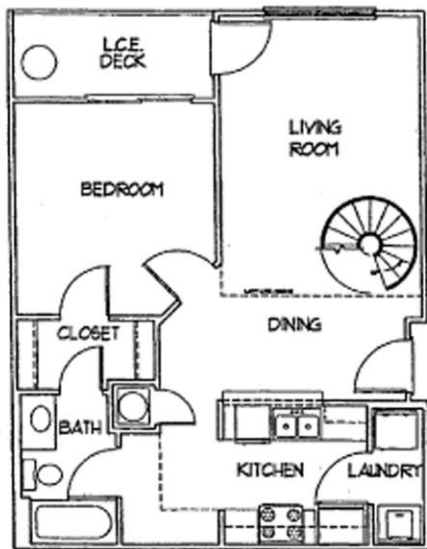

First Level

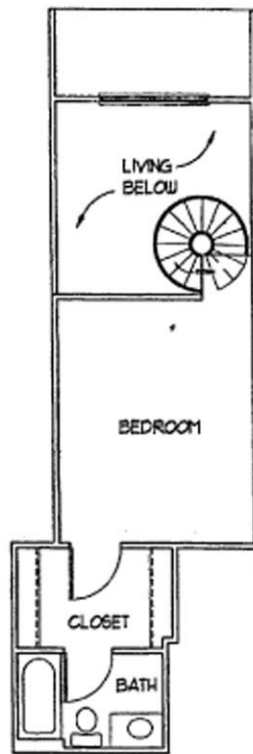

Second Level

UNIT A2 - LOFT

2 Bedroom - 2 Bath

UNIT NUMBERS:
B-523

THIS FLOOR PLAN AND THE DIMENSIONS AND SQUARE FOOTAGE CALCULATIONS SHOWN HEREIN ARE ONLY APPROXIMATIONS. BUYER/LEASER WHO IS CONCERNED ABOUT ANY REPRESENTATIONS REGARDING THIS FLOOR PLAN SHOULD CONSULT WITH AN ARCHITECT OR ANOTHER PROFESSIONAL AS TO THE DIMENSIONS, VERTICALS, AND SQUARE FOOTAGE OF THE UNIT.

PEACHTREE WALK, A CONDOMINIUM

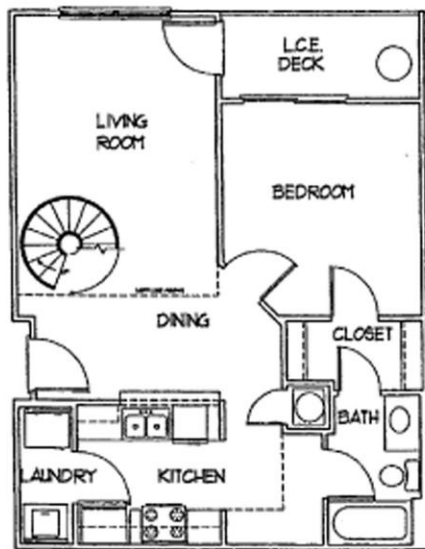

First Level

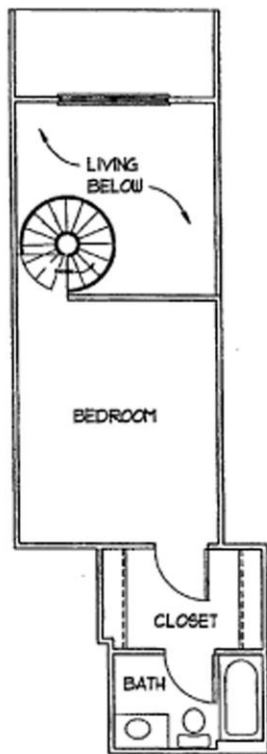

Second Level

UNIT A2 - LOFT (M)

2 Bedroom - 2 Bath

UNIT NUMBERS:
A-501

THE FLOOR PLAN AND THE DIMENSIONS AND SQUARE FOOTAGE
CALCULATIONS SHOWN HEREIN ARE ONLY APPROXIMATIONS. ANY
UNIT OWNER WHO IS CONCERNED ABOUT ANY REPRESENTATIONS
REGARDING THIS FLOOR PLAN SHOULD CONSULT WITH AN
INSPECTOR AS TO THE DIMENSIONS, MEASUREMENTS, AND
SQUARE FOOTAGE OF THE UNIT.

PEACHTREE WALK, A CONDOMINIUM

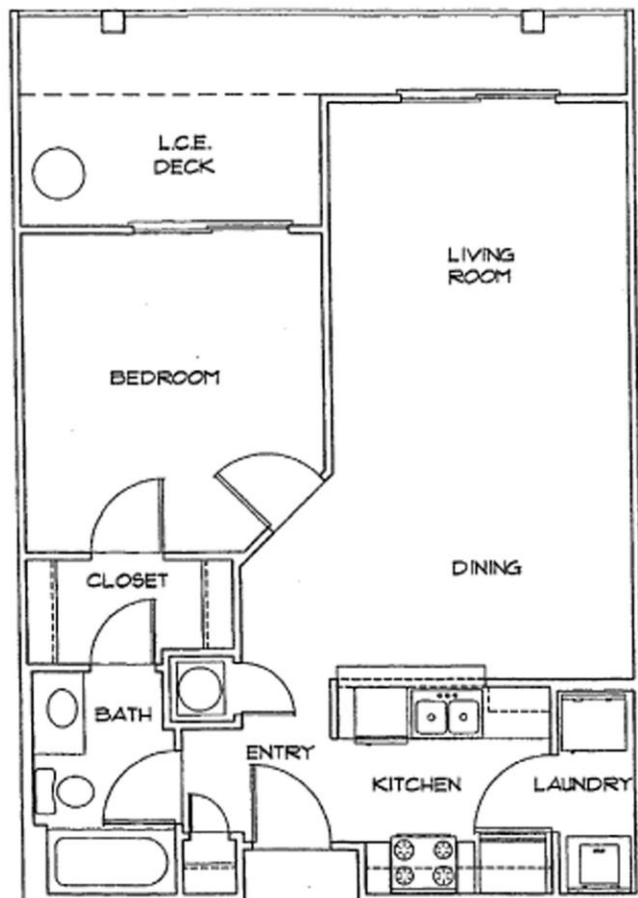

UNIT A3

1 Bedroom - 1 Bath

UNIT NUMBERS:

B-111, B-211, B-311, B-411

THE FLOOR PLAN AND THE DIMENSIONS AND SQUARE FOOTAGE
CALCULATIONS SHOWN HEREIN ARE ONLY APPROXIMATIONS. ANY
UNIT OWNER WHO IS CONCERNED ABOUT ANY REPRESENTATIVE'S
RESPONDING TO THIS FLOOR PLAN SHOULD CONSULT WITH AN
ARCHITECT OR AN ATTORNEY AS TO THE DIMENSIONS, MEASUREMENTS, AND
SQUARE FOOTAGE OF THE UNIT.

PEACHTREE WALK, A CONDOMINIUM

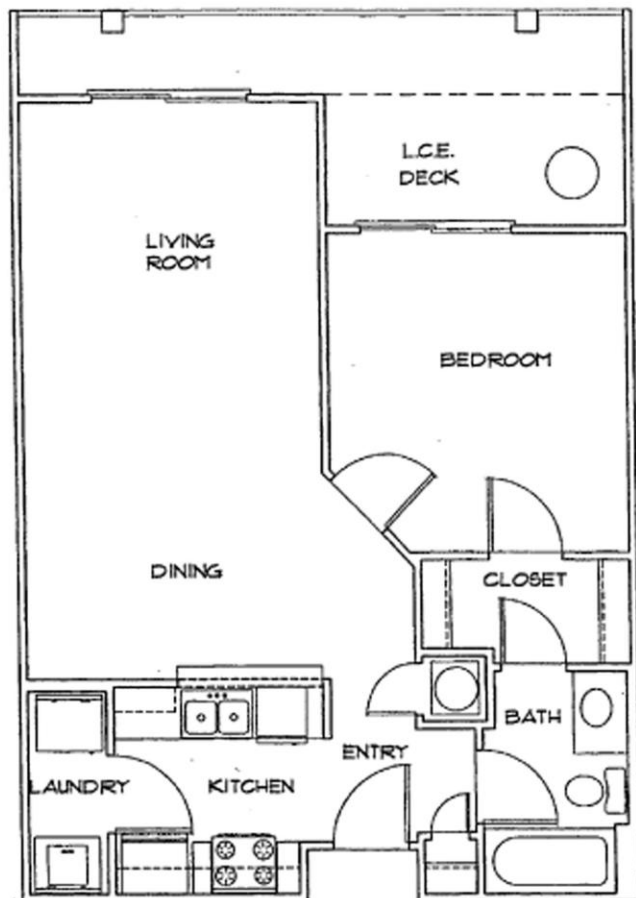

UNIT A3 (M)

1 Bedroom - 1 Bath

UNIT NUMBERS:

A-111, A-211, A-311, A-411

THIS FLOOR PLAN AND THE DIMENSIONS AND SQUARE FOOTAGE CALCULATIONS SHOWN HEREIN ARE ONLY APPROXIMATIONS, AND THE OWNER WHO IS CONCERNED MUST GET PROFESSIONAL ASSISTANCE REGARDING THIS FLOOR PLAN SHOULD DO HEAVY CONSTRUCTION AS TO THE DIMENSIONS, MEASUREMENTS, AND SQUARE FOOTAGE OF THE UNIT.

PEACHTREE WALK, A CONDOMINIUM

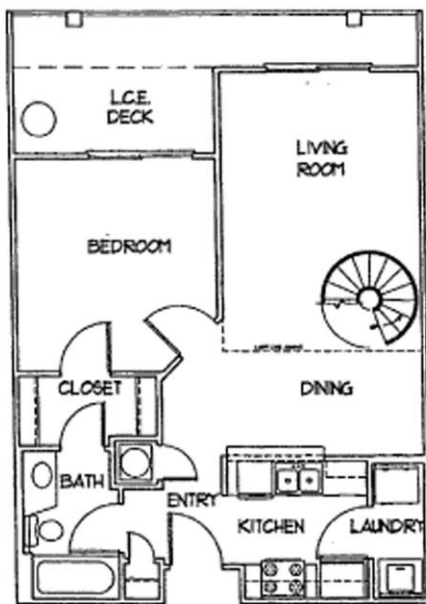

First Level

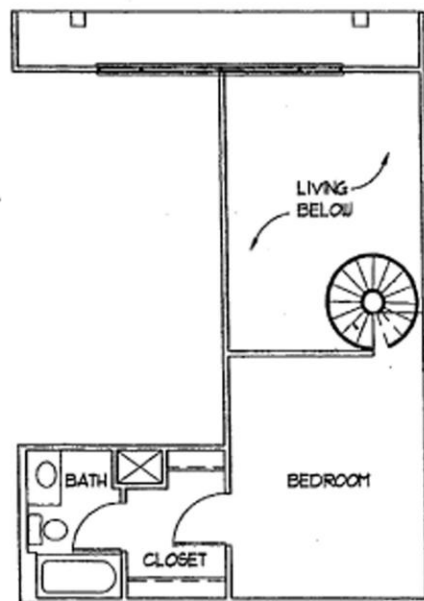

Second Level

UNIT A3 - LOFT

2 Bedroom - 2 Bath

UNIT NUMBERS:
B-511

THE FLOOR PLAN AND THE DIMENSIONS AND SQUARE FOOTAGE
CALCULATIONS SHOWN HEREON ARE ONLY APPROXIMATIONS. ANY
UNIT OWNER WHO IS CONCERNED ABOUT ANY REPRESENTATIONS
REGARDING THIS FLOOR PLAN SHOULD OBTAIN AN
INVESTIGATION AS TO THE DIMENSIONS, MEASUREMENTS, AND
SQUARE FOOTAGE OF THE UNIT.

PEACHTREE WALK, A CONDOMINIUM

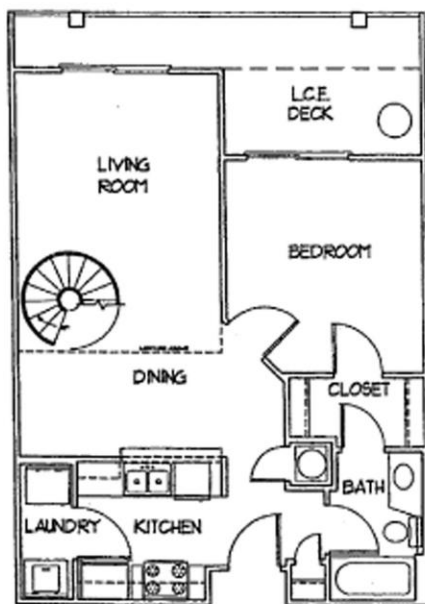

First Level

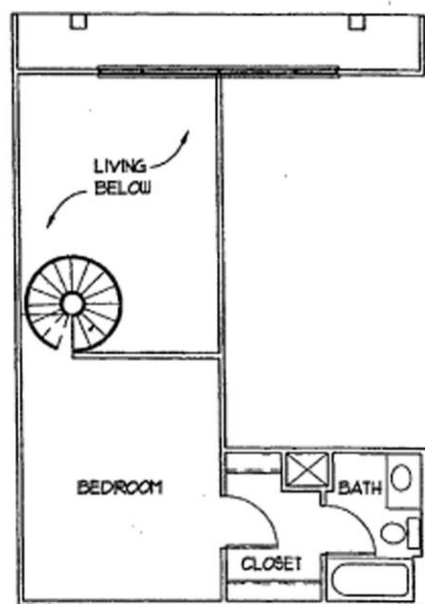

Second Level

UNIT A3 - LOFT (M)

2 Bedroom - 2 Bath

UNIT NUMBERS:
A-511

THIS FLOOR PLAN AND THE DIMENSIONS AND SQUARE FOOTAGE CALCULATIONS SHOWN HEREON ARE ONLY APPROXIMATIONS. ANY UNIT OWNER WHO IS CONCERNED ABOUT ANY REPRESENTATIONS REGARDING THIS FLOOR PLAN SHOULD TO HAVE HIS OWN INVESTIGATION AS TO THE DIMENSIONS, MEASUREMENTS, AND SQUARE FOOTAGE OF THE UNIT.

PEACHTREE WALK, A CONDOMINIUM

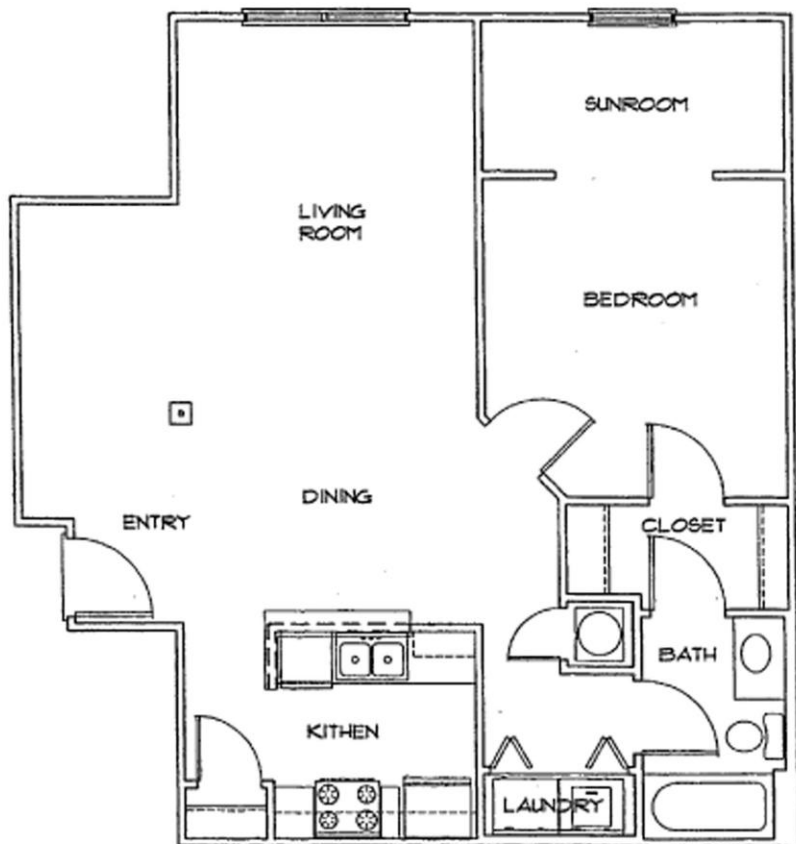

UNIT A4

1 Bedroom - 1 Bath

UNIT NUMBERS:
B-108

THE FLOOR PLAN AND THE DIMENSIONS AND SQUARE FOOTAGE
CALCULATED THEREIN ARE ONLY APPROXIMATIONS. ANY
UNIT OWNER WHO IS CONCERNED ABOUT ANY REPRESENTATIONS
INDICATED THIS FLOOR PLAN SHOULD DO HIS/HER OWN
INVESTIGATION AS TO THE DIMENSIONS, MEASUREMENTS, AND
SQUARE FOOTAGE OF THE UNIT.

PEACHTREE WALK, A CONDOMINIUM

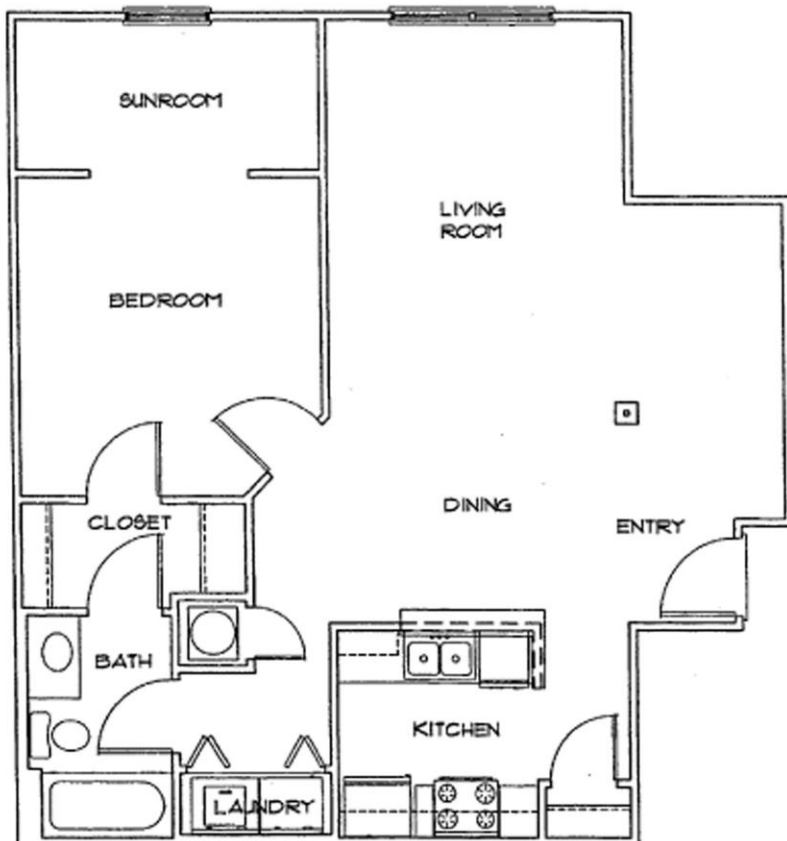

UNIT A4 (M)

1 Bedroom - 1 Bath

UNIT NUMBERS:
A-114

THIS FLOOR PLAN AND THE DIMENSIONS AND SQUARE FOOTAGE
CALCULATIONS SHOWN HEREON ARE ONLY APPROXIMATIONS AND
THEY SHOULD NOT BE CONSIDERED AS A GUARANTEE. THE
OWNER SHOULD CONSULT WITH A PROFESSIONAL ARCHITECT
REGARDING THE FLOOR PLAN SHOULD DO MEASURE OWN
DIMENSIONS AS TO THE DIMENSIONS, MEASUREMENTS, AND
SQUARE FOOTAGE OF THE UNIT.

PEACHTREE WALK, A CONDOMINIUM

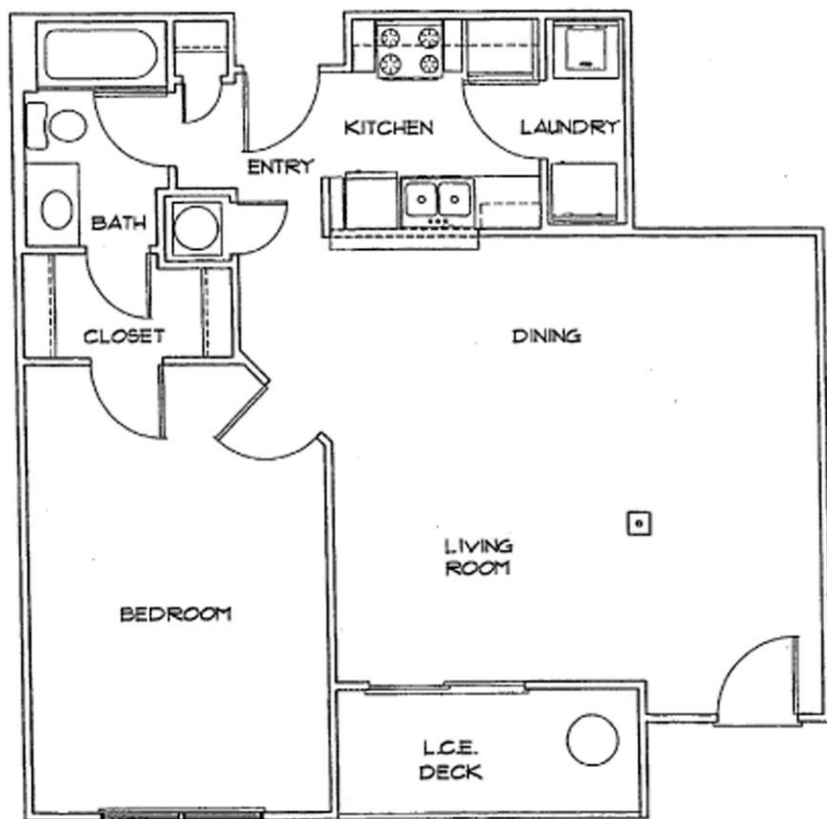

UNIT A5

1 Bedroom - 1 Bath

UNIT NUMBERS:
A-120

THIS FLOOR PLAN AND THE DIMENSIONS AND SQUARE FOOTAGE
ON (PLACEMENT) THEREIN ARE ONLY APPROXIMATIONS AND
UNIT OWNER WHO IS CONCERNED ABOUT ANY IMPROVEMENTS
PROPOSED THIS FLOOR PLAN SHOULD CONSULT WITH OWN
REPRESENTATIVE AS TO THE DIMENSIONS, MEASUREMENTS, AND
SQUARE FOOTAGE OF THE UNIT.

PEACHTREE WALK, A CONDOMINIUM

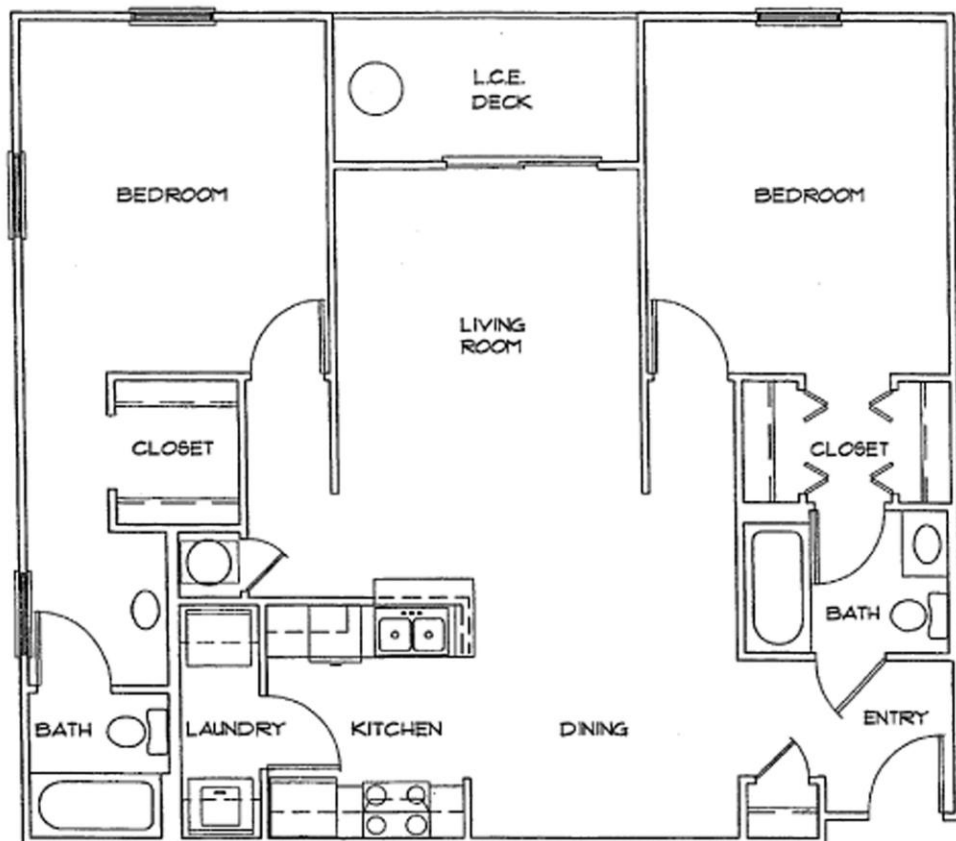

UNIT B - DECK

2 Bedroom - 2 Bath

UNIT NUMBERS:

A-103, A-203, A-214, A-220, A-303,
 A-314, A-320, A-403, A-414, A-420,
 A-503, A-514, A-520
 B-106, B-202, B-206, B-207, B-215,
 B-302, B-306, B-307, B-315, B-402,
 B-406, B-407, B-415, B-502, B-506,
 B-507, B-515

THIS FLOOR PLAN AND THE DIMENSIONS AND SQUARE FOOTAGE
 CALCULATIONS SHOWN HEREIN ARE ONLY APPROXIMATIONS. ANY
 UNIT OWNER WHO IS CONCERNED ABOUT ANY DISCREPANCIES
 REGARDING THIS FLOOR PLAN SHOULD CONSULT WITH THE
 ARCHITECT AS TO THE DIMENSIONS, MEASUREMENTS AND
 SQUARE FOOTAGE OF THE UNIT.
 WINDOW CONFIGURATION MAY VARY BASED ON UNIT LOCATION
 AND ORIENT.

PEACHTREE WALK, A CONDOMINIUM

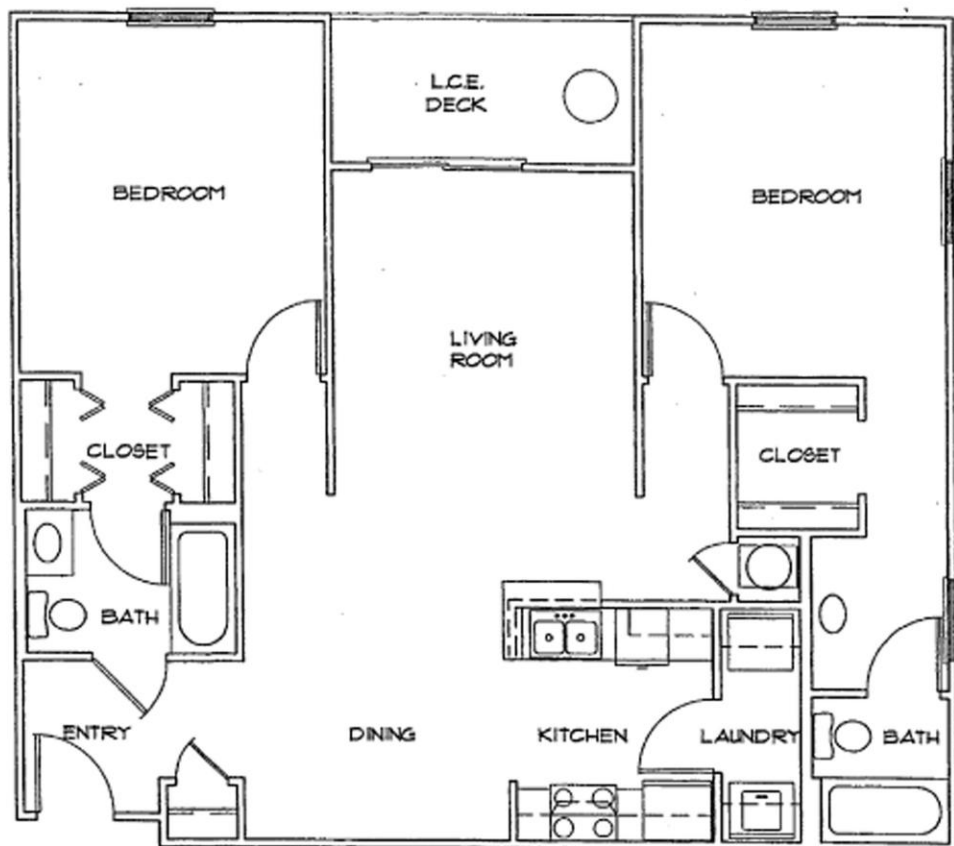

UNIT B - DECK (M)

2 Bedroom - 2 Bath

UNIT NUMBERS:

A-207, A-221, A-307, A-321,
 A-407, A-421, A-507, A-521
 B-201, B-208, B-221, B-301,
 B-308, B-321, B-401, B-408,
 B-421, B-501, B-508, B-521

THIS FLOOR PLAN AND THE DIMENSIONS AND SQUARE FOOTAGE
 CALL OUTS SHOWN HEREIN ARE ONLY APPROXIMATIONS. ANY
 UNIT OWNER WHO IS CONCERNED ABOUT ANY REPRESENTATIONS
 REGARDING THIS FLOOR PLAN SHOULD GO THROUGH A
 INSPECTION AS TO THE DIMENSIONS, MEASUREMENTS, AND
 SQUARE FOOTAGE OF THE UNIT.
 WINDOW CONFIGURATION MAY VARY BASED ON UNIT LOCATION
 AND BUILDING.

PEACHTREE WALK, A CONDOMINIUM

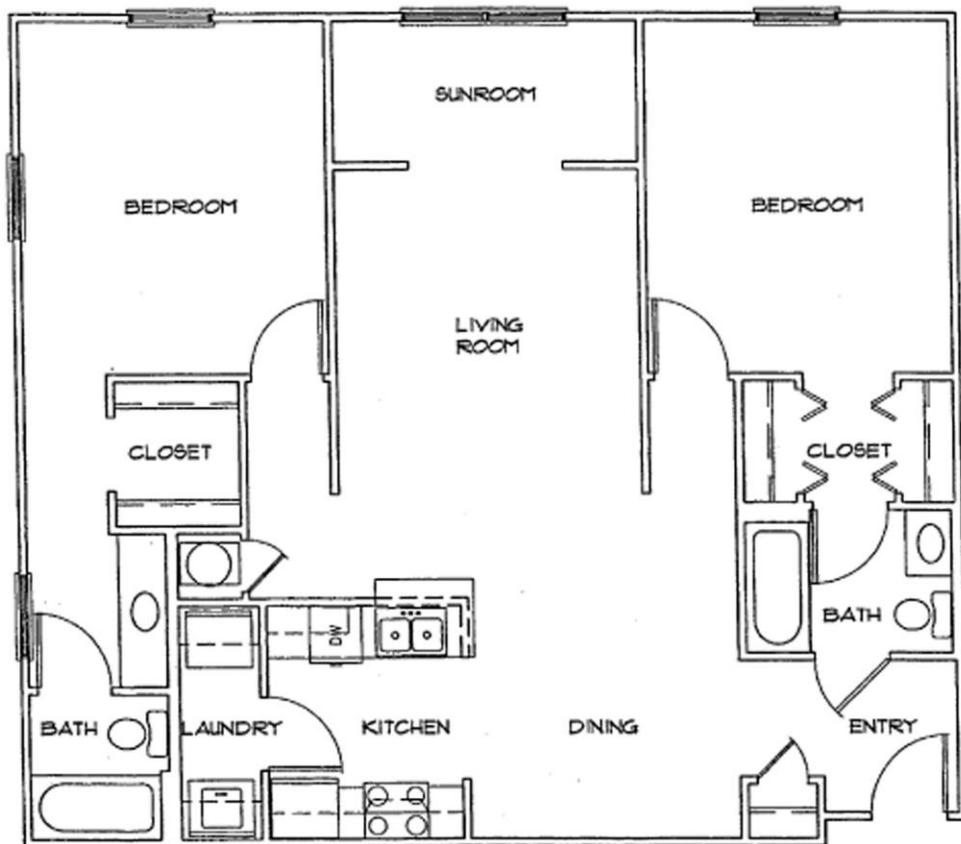

UNIT B - SUNROOM

2 Bedroom - 2 Bath

UNIT NUMBERS:
B-102, B-107, B-115

THIS FLOOR PLAN AND THE DIMENSIONS AND SQUARE FOOTAGE
CALCULATIONS SHOWN HEREIN ARE ONLY APPROXIMATIONS. ANY
UNIT OWNER WHO IS CONCERNED ABOUT ANY REPRESENTATIONS
REGARDING THIS FLOOR PLAN SHOULD CONSULT HIS OWN
SURVEYOR AS TO THE DIMENSIONS, MEASUREMENTS, AND
SQUARE FOOTAGE OF THE UNIT.

WHEN CONSTRUCTION MAY VARY BASED ON UNIT LOCATIONS
AND BUILDINGS.

PEACHTREE WALK, A CONDOMINIUM

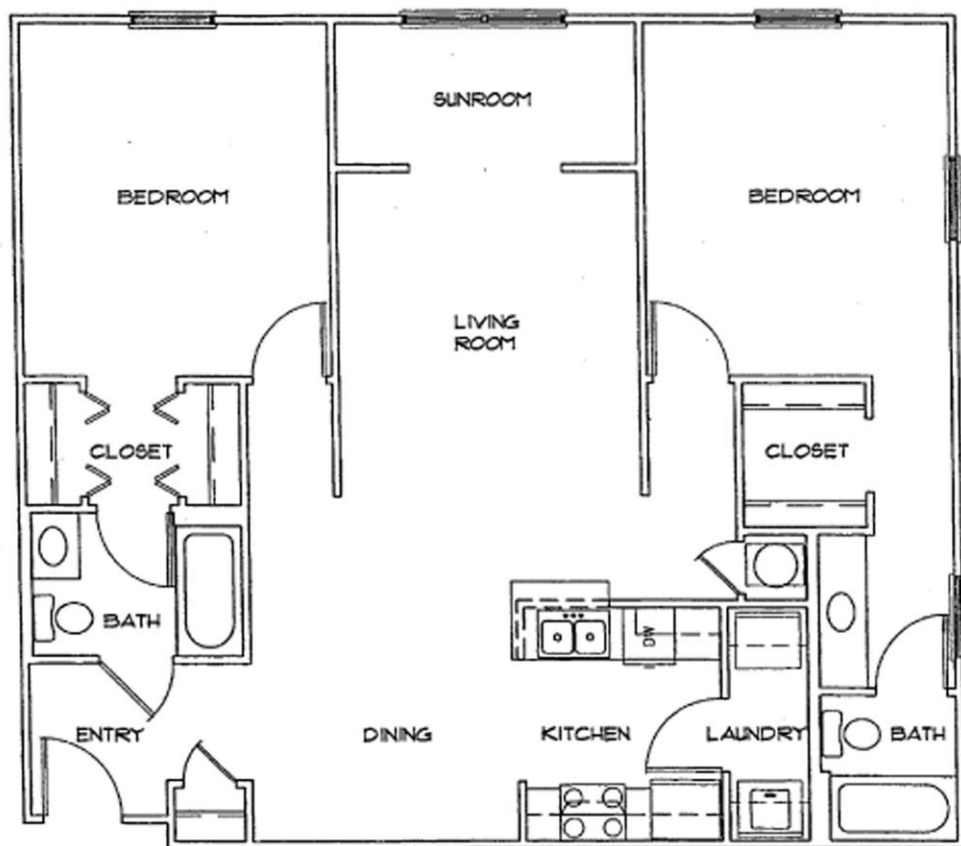

UNIT B - SUNROOM (M)

2 Bedroom - 2 Bath

UNIT NUMBERS:

A-107, A-121

B-107, B-121

THIS FLOOR PLAN AND THE DIMENSIONS AND SQUARE FOOTAGE
CALCULATIONS SHOWN HEREIN ARE ONLY APPROXIMATIONS. ANY
UNIT OWNER WHO IS CONCERNED ABOUT ANY DISCREPANCIES
REGARDING THIS FLOOR PLAN SHOULD DO HER/OVER OWN
INVESTIGATION AS TO THE DIMENSIONS, MEASUREMENTS, AND
SQUARE FOOTAGE OF THE UNIT.

WASHER CONFIGURATION MAY VARY BASED ON UNIT LOCATION
AND BUILDING.

PEACHTREE WALK, A CONDOMINIUM

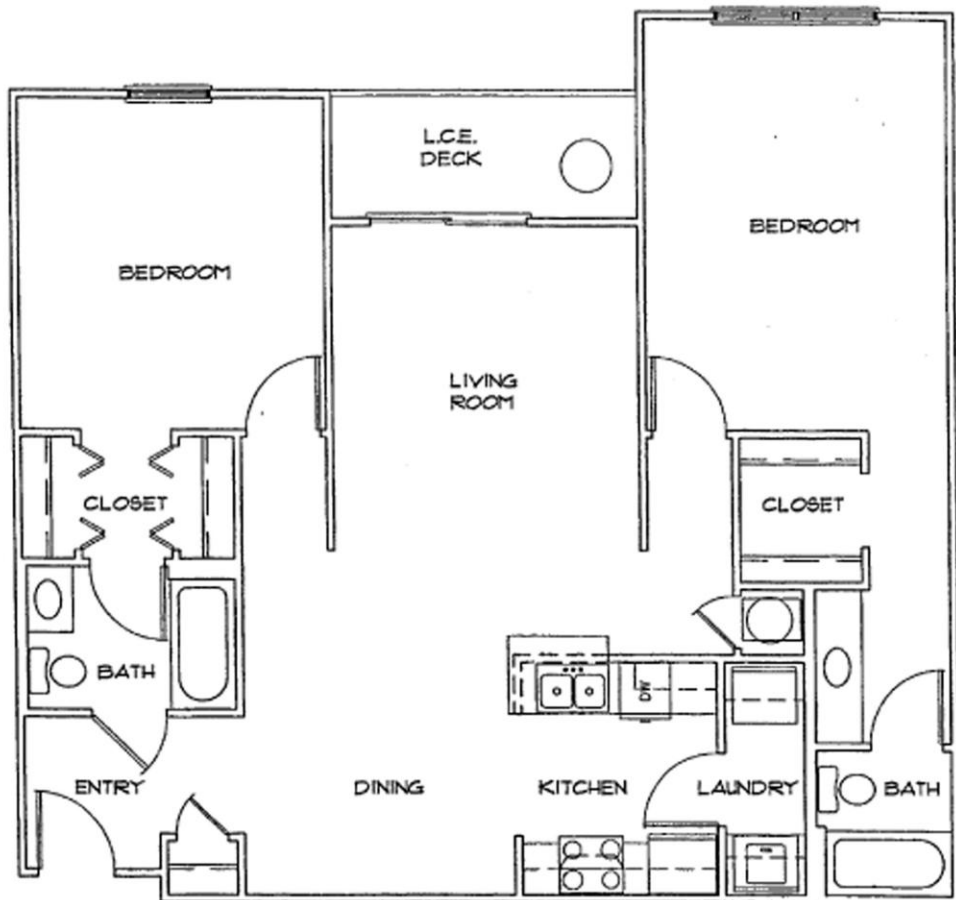

UNIT B1

2 Bedroom - 2 Bath

UNIT NUMBERS:
 B-109, B-209, B-309, B-409,
 B-509

THIS FLOOR PLAN AND THE DIMENSIONS AND SQUARE FOOTAGE
 CALCULATIONS SHOWN HEREIN ARE ONLY APPROXIMATIONS. ANY
 UNIT OWNER WHO IS CONCERNED ABOUT ANY REPRESENTATIONS
 REGARDING THIS FLOOR PLAN SHOULD CONSULT WITH AN
 ARCHITECTURE AS TO THE DIMENSIONS, MEASUREMENTS, AND
 SQUARE FOOTAGE OF THE UNIT.

PEACHTREE WALK, A CONDOMINIUM

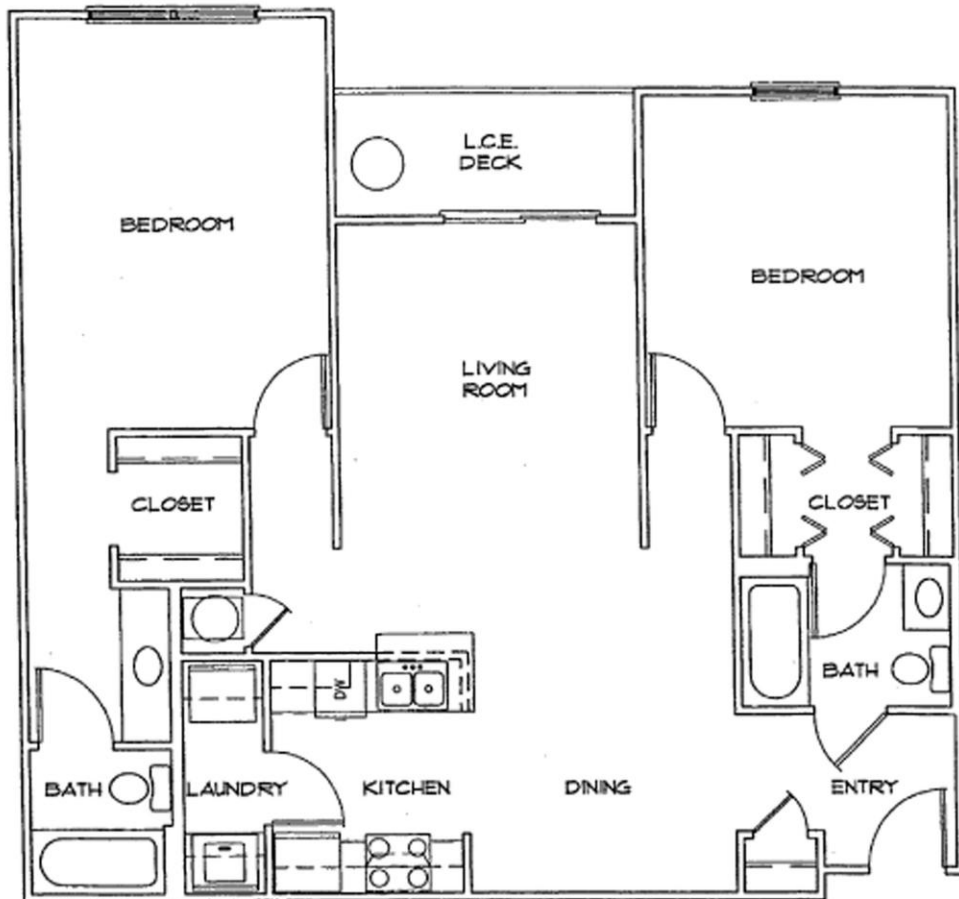

UNIT B1 (M)

2 Bedroom - 2 Bath

UNIT NUMBERS:

A-113, A-213, A-313, A-413, A-513

THIS FLOOR PLAN AND THE DIMENSIONS AND SQUARE FOOTAGE CALCULATIONS THEREON ARE ONLY APPROXIMATIONS. ANY UNIT OWNER WHO IS CONCERNED ABOUT ANY REPRESENTATIONS REGARDING THIS FLOOR PLAN SHOULD DO HIS/HER OWN INVESTIGATION AS TO THE DIMENSIONS, MEASUREMENTS, AND SQUARE FOOTAGE OF THE UNIT.

PEACHTREE WALK, A CONDOMINIUM

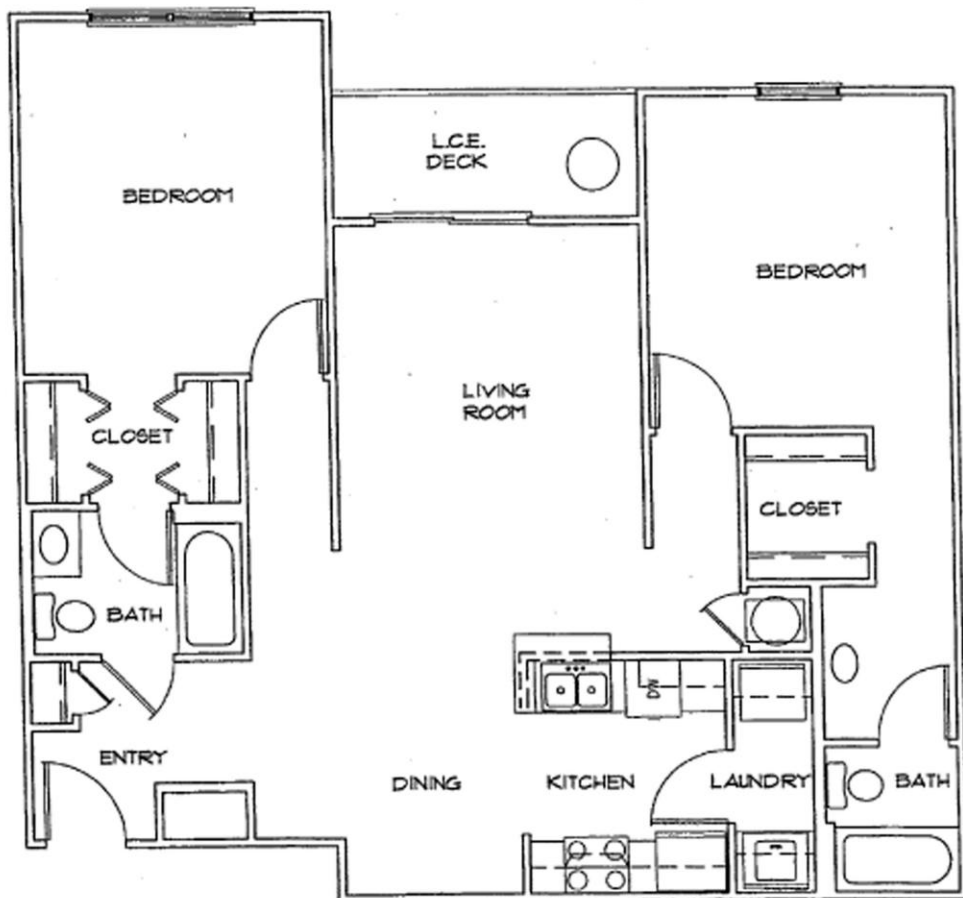

UNIT B2

2 Bedroom - 2 Bath

UNIT NUMBERS:

B-112, B-212, B-312, B-412, B-512

THIS FLOOR PLAN AND THE DIMENSIONS AND SQUARE FOOTAGE CALCULATIONS SHOWN HEREON ARE ONLY APPROXIMATIONS. ANY UNIT OWNER WHO IS CONCERNED ABOUT ANY REPRESENTATIONS REGARDING THIS FLOOR PLAN SHOULD DO HIS/HER OWN INVESTIGATION AS TO THE DIMENSIONS, MEASUREMENTS, AND SQUARE FOOTAGE OF THE UNIT.

PEACHTREE WALK, A CONDOMINIUM

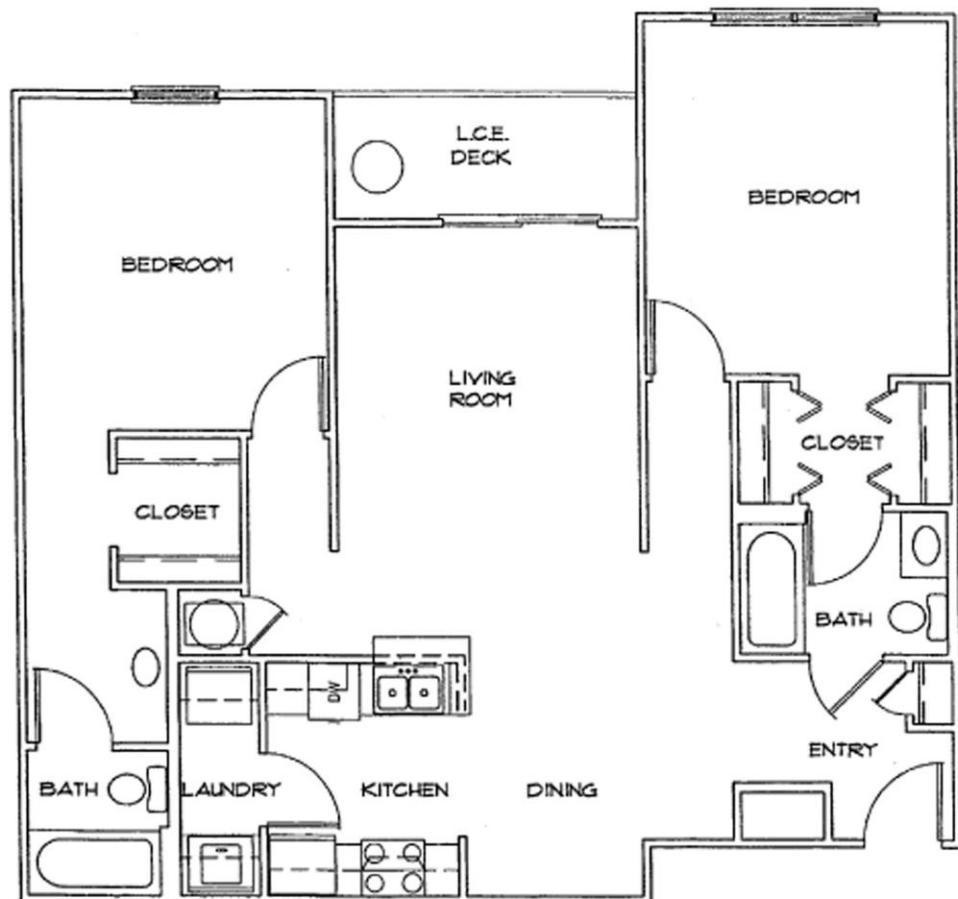

UNIT B2 (M)

2 Bedroom - 2 Bath

UNIT NUMBERS:

A-110, A-210, A-310, A-410, A-510

THIS FLOOR PLAN AND THE DIMENSIONS AND SQUARE FOOTAGE CALCULATIONS SHOWN HEREON ARE ONLY APPROXIMATIONS. ANY UNIT OWNER WHO IS CONCERNED ABOUT ANY NEIGHBORING UNIT SHOULD REQUEST THE FLOOR PLAN SHOULD SO IMMEDIATELY CONTACT THE ARCHITECT AS TO THE DIMENSIONS, MEASUREMENTS, AND SQUARE FOOTAGE OF THE UNIT.

PEACHTREE WALK, A CONDOMINIUM

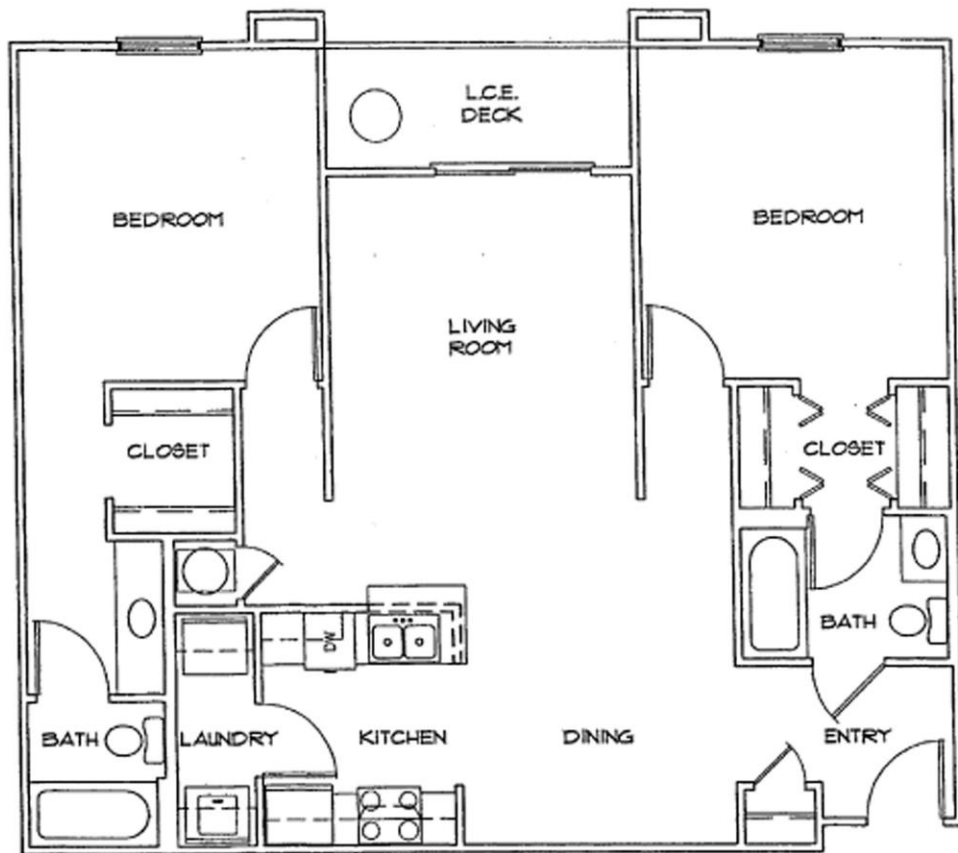

UNIT B3

2 Bedroom - 2 Bath

UNIT NUMBERS:

B-114, B-214, B-314, B-414, B-514

THIS FLOOR PLAN AND THE DIMENSIONS AND SQUARE FOOTAGE CALCULATIONS SHOWN HEREON ARE ONLY APPROXIMATIONS, WHY UNIT OWNERS WHO IS CONCERNED ABOUT ANY REPRESENTATIONS REGARDING THIS FLOOR PLAN SHOULD CONSULT WITH AN INVESTIGATOR AS TO THE DIMENSIONS, MEASUREMENTS, AND SQUARE FOOTAGE OF THE UNIT.

PEACHTREE WALK, A CONDOMINIUM

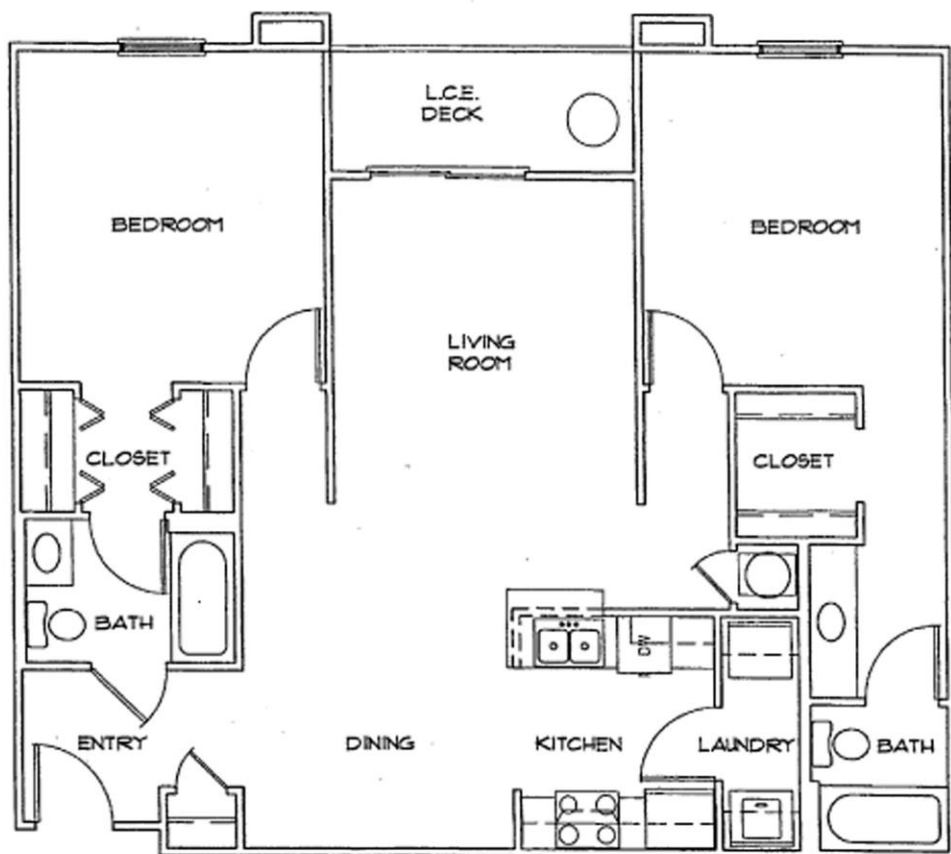

UNIT B3 (M)

2 Bedroom - 2 Bath

UNIT NUMBERS:

A-108, A-208, A-308, A-408,
A-508

THE FLOOR PLAN AND THE DIMENSIONS AND SQUARE FOOTAGE
CALCULATIONS SHOWN HEREIN ARE ONLY APPROXIMATIONS. ANY
UNIT OWNER WHO IS CONCERNED ABOUT ANY REPRESENTATIVE
REGARDING THE FLOOR PLAN SHOULD DO HIS/HER OWN
INVESTIGATION AS TO THE DIMENSIONS, MEASUREMENTS, AND
SQUARE FOOTAGE OF THE UNIT.

PEACHTREE WALK, A CONDOMINIUM

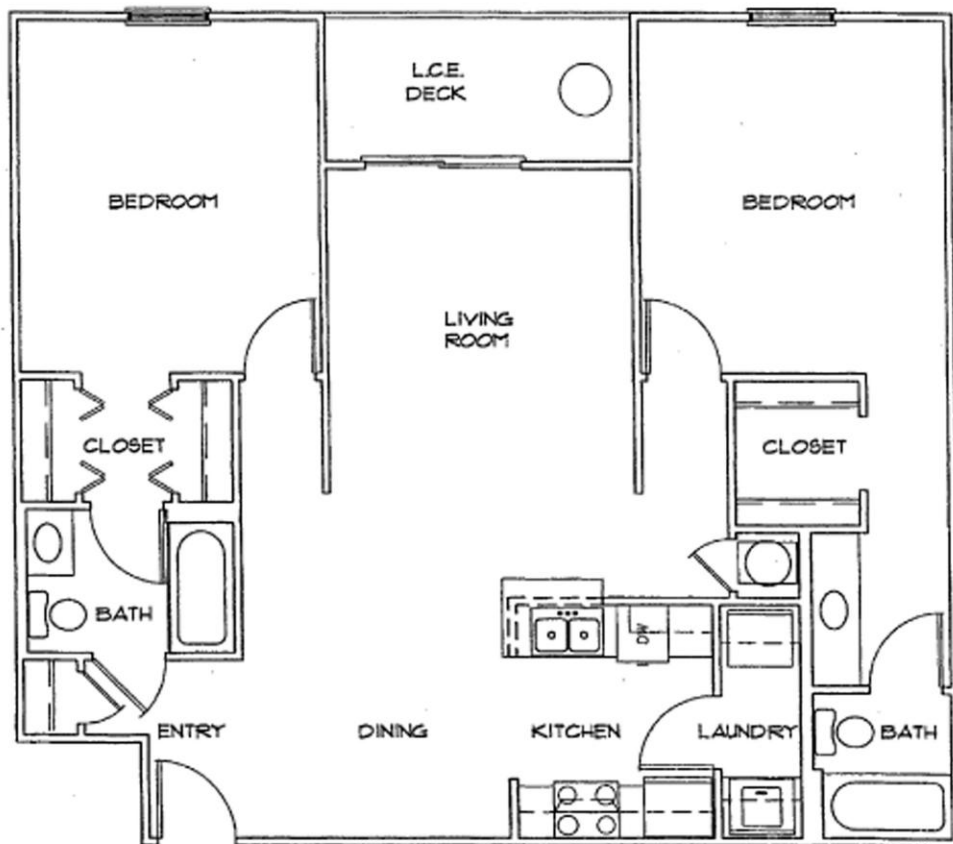

UNIT B4 - DECK

2 Bedroom - 2 Bath

UNIT NUMBERS:

B-203, B-303, B-403, B-503

THIS FLOOR PLAN AND THE DIMENSIONS AND SQUARE FOOTAGE
 CALCULATIONS SHOWN HEREON ARE ONLY APPROXIMATIONS. ANY
 UNIT OWNER WHO IS CONCERNED ABOUT ANY REPRESENTATIONS
 REGARDING THIS FLOOR PLAN SHOULD GO FURTHER AND
 INVESTIGATE AS TO THE DIMENSIONS, MEASUREMENTS, AND
 SQUARE FOOTAGE OF THE UNIT.

PEACHTREE WALK, A CONDOMINIUM

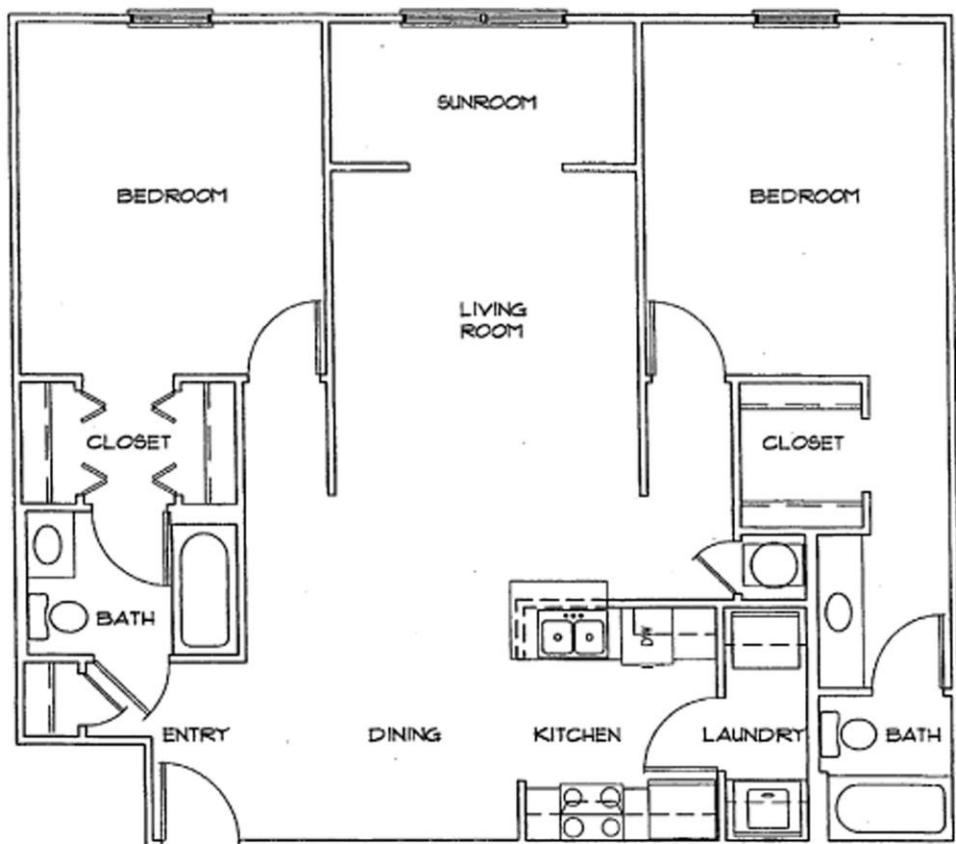

UNIT B4 - SUNROOM

2 Bedroom - 2 Bath

UNIT NUMBERS:
B-103

THIS FLOOR PLAN AND THE DIMENSIONS AND SQUARE FOOTAGE CALCULATIONS SHOWN HEREIN ARE ONLY APPROXIMATIONS. ANY UNIT OWNER WHO IS CONSIDERING BUYING ANY REPRESENTATIONS REGARDING THE FLOOR PLAN SHOULD DO HIS/HER OWN INVESTIGATION AS TO THE DIMENSIONS, MEASUREMENTS, AND SQUARE FOOTAGE OF THE UNIT.

PEACHTREE WALK, A CONDOMINIUM